

# Manual

## Digital I/O Extender Set



Type  
Release

17633  
1.0

© 04/2007 by Wiesemann & Theis GmbH

Subject to error and alteration:

Since it is possible that we make mistakes, you mustn't use any of our statements without verification. Please, inform us of any error or misunderstanding you come about, so we can identify and eliminate it as soon as possible.

Carry out your work on or with W&T products only to the extent that they are described here and after you have completely read and understood the manual or guide. We are not liable for unauthorized repairs or tampering. When in doubt, check first with us or with your dealer.

Although the low bandwidth and large voltage swing of digital I/O signals make them essentially less sensitive to external noise than for example serial data signals, in some case the operating conditions necessitate transmission procedures which are completely resistant to noise effects along the transmission line.

*Glass fibers* used as a transmission medium meet these requirements ideally while also offering the advantage of galvanic isolation up to virtually any level between the connected subscribers. In installations which are subject to the risk of severe weather conditions, such as in outdoor locations or between distant buildings, such a solution ensures a permanently reliable connection even under adverse conditions.

Wiesemann & Theis offers a whole family of various glass fiber interfaces which allow conversion of standard interfaces into an optical interface for connecting glass fiber cable.

The W&T Digital-I/O Extender Set, which carries the digital I/O signals over glass fiber optic cable using a multiplexing procedure, is described on the following pages along with its technical data and connection examples.

Up-to-date information about new product developments can be found in the Internet at <http://www.wut.de> or in the e-mail updates from the W&T Interface Club, which you can sign up for on the W&T homepage.

**Table of Contents**

Function ..... 17

Supply Voltage ..... 17

Galvanic Isolation ..... 17

Housing ..... 18

Glass Fiber Interface ..... 18

Digital-I/O Port ..... 18

Terminal Assignments ..... 19

Supply Voltage Input (Vcc) ..... 19

Digital Inputs ..... 20

Digital Outputs ..... 21

Cable break behavior ..... 22

Technical Data ..... 23

## Digital-I/O Extender Set, Model 17633

### Function

The W&T Digital-I/O Extender Set, Model 17633 enables sending of digital I/O signals bi-directionally over a glass fiber optic cable.

The set consists of two digital-I/O <> glass fiber optic converters and supports two I/O channels in each direction. A special communications protocol between the converters is used for transmitting over the glass fiber optic cable, so that the converters can only be used in pairs.

### Supply Voltage

The signal converters are powered by an integrated switched regulator. This regulator has a variable input voltage range and enables powering of the converters using the supplied AC power adapter or alternately by using any DC or AC voltage between 12 and 24 volts. The supply voltage is reverse polarity protected and can be implemented on the underside of the converters using the included plug-in 2-pole screw terminal.

### Galvanic Isolation

Within the signal converters the I/O connections are galvanically isolated from the supply voltage up to min. 1000 V using a DC/DC converter. The level of galvanic isolation between the two converters and thereby between the I/O terminal points is determined primarily by the length of the glass fiber optic cable used.

## Housing

The digital-I/O <> glass fiber optic are integrated inside a DIN EN 50022-35 housing for mounting on DIN rails.

To configure the cable break behavior you must open the Interface housing so that the DIL switches on the Digital-I/O Interface Module are accessible. To do this, slide the housing cover with the attached circuit board out of the housing body by grabbing the ST connector.

## Glass Fiber Interface

Common ST connectors are used for connecting the glass fiber optic cable. A version with SMA connectors is also available as a special on request.

The light used for data transmission has a wavelength of 820 nm. Common 50/125  $\mu\text{m}$  or 62,5/125  $\mu\text{m}$  multimode duplex glass fiber optic cable is used, which thanks to its wide use in networking is easily available and inexpensive. This means that even existing glass fiber optic sections which are intended for use in networks can be used for sending digital signals. Depending on the attenuation factor of the glass fiber optic cable used, data transmission over distances of up to 3800 meters is possible.

## Digital-I/O Port

The Digital-I/O-Port is configured as a plug-in 3.5mm terminal block so that the connected in- and outputs can be disconnected from the signal converter at any time without having to unscrew anything.

Effective protection diodes protect all digital inputs against transients which exceed the permissible input voltage of the inputs by +/- 30V.

When the inputs are continuously switched with higher voltage, an external current limiter must be provided to prevent thermal destruction of the protection diodes.



Driver chips are used for the digital outputs which provide integrated protection against short circuit, overload and thermal destruction.

### LEDs and Terminal Assignments

The converter features two LED's, with the *Power* LED indicating correct supply voltage. The *Data* LED is not connected.

The configuration of the signal and supply terminals and the pin configuration of the interfaces can be found on the device label as well as in the following illustration:

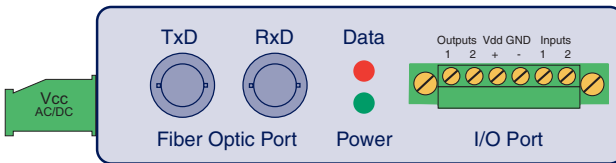

### Supply Voltage Input (Vcc)

The supply voltage is connected to the screw terminals on the underside of the housing. The included AC power adapters are equipped with a special plug on the low-voltage side.

Alternately, any desired voltage of 12V to 24V can be used for power. Since the signal converters can be operated with DC or AC voltage, no special precautions are necessary with respect to the polarity of the supply voltage. To prevent cable break, we recommend in this case providing wire ferrules on the ends of the conductors.

The *Vdd* terminal on the front side supplies only the switching outputs and must be connected to a DC voltage.



## Digital Inputs

The basic wiring of the inputs for the Digital-I/O Extender Set can be seen in the following illustration:

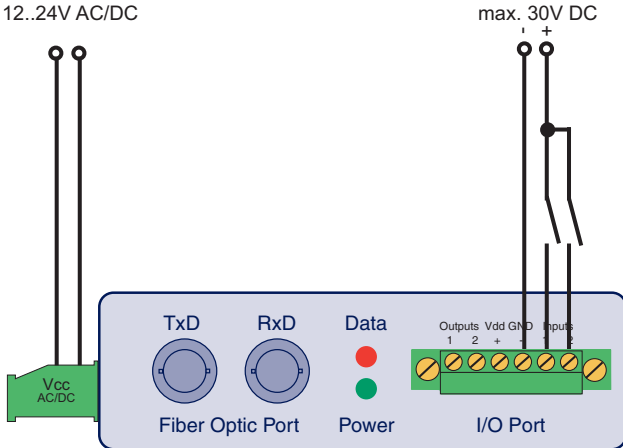

The permissible range of the input voltage for the digital inputs of the Digital-I/O Extender Set is  $\pm 30V$  with respect to reference ground.

The switching threshold of the inputs is  $8V \pm 1V$ . Voltage below this are recognized as an *OFF* - signal. The converter recognizes voltage over  $8V$  as an *ON* - signal. Input voltages between  $7V$  and  $9V$  should be avoided, since a reproducible association with a particular signal level is not possible.

The lines to the digital inputs should not be longer than necessary.



### Digital Outputs

The basic wiring of the switching outputs for the Digital-I/O Extender Set can be seen in the following illustration:

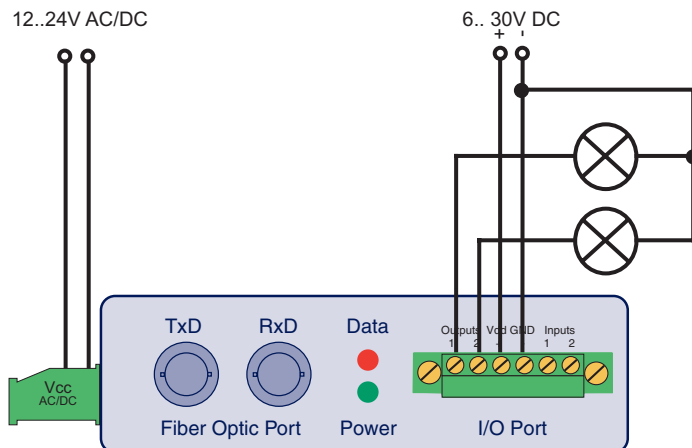

The two digital outputs of the Digital-I/O Extenders are current sourcing. The supply voltage for the outputs may be between +6 V and +30 V DC and is provided at terminals Vdd and GND.

Each of the outputs can switch a maximum current of 0.5A. If loads with an inductive component (e.g. relays, contactors, solenoids etc.) need to be switched, the outputs must be additionally protected using recovery diodes.

The outputs have thermal overload protection and are short circuit protected. In the OFF state a very low current of approx. 10µA is used to check whether the outputs are switched to a load. If LEDs are connected to the outputs, this can result in a slight glow even in the rest state.

When sizing the output voltage supply, the required current must always be taken into consideration. If the selected voltage for supplying the loads varies between 12V and 24V DC, the signal converter and the switched loads can be supplied from the same source.

### Cable break behavior

Should the glass fiber connection be interrupted or if the glass fiber cable is not connected, the default response is for all digital outputs to go directly to the *Off* state. A different response can be configured individually for each channel using DIL switches inside the unit. Simply set the DIL switches for the corresponding in- and outputs in both Digital-I/O <-> Glass Fiber converters to *ON*. The names of the DIL switches *In1*, *In2*, *Out1* and *Out2* can be found on the circuit board near the switch.

To change for example the cable break behavior of the first I/O channel, set DIL switch *In1* on the first interface AND DIL switch *Out1* on the second interface to *ON*. Now when there is a cable break or the glass fiber cable is disconnected, the output goes directly to the *ON* state.

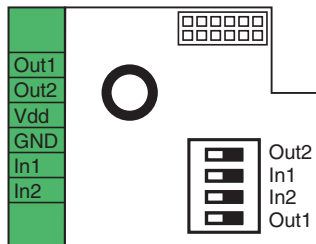

In this way each of the four channels can be configured individually as desired.

**Note: Changing the setting of a DIL switch on only one Interface causes the signal to be sent inverted. When voltage is present on the input the corresponding output is turned off.**



**Technical Data**

Transmitted signals:	2x Digital In, 2x Digital Out
Digital-I/O connector:	6-pole plug-in screw terminal
Digital outputs:	2x Digital Out, 6V-30V, 0.5A, Short circuit protected
Digital inputs:	2x Digital In, max. input voltage $\pm 30V$ , reverse polarity protected within this range Switching threshold $8V \pm 1V$ „ON“-current= 2.2 mA
Signal delay:	Input to output: max. 250 $\mu$ s
Signal bandwidth:	max. 1 KHz
Glass fiber connector:	ST connectors SMA connectors on request
Fiber medium:	Duplex multimode glass fiber cable
maximum distance:	50/125 $\mu$ m: typ. 3200m, min. 1400m @3dB/km 62.5/125 $\mu$ m: typ. 3800m, min. 2200m @3.5dB/km 200um PCS fiber: typ. 2500m, min. 1500m @8dB/km
Optical budget:	50/125 $\mu$ m: typ. 9.6dB, min. 4,2dB 62.5/125 $\mu$ m: typ. 13.4dB, min. 8.0dB 200um PCS fibers: typ. 20dB, min 12dB
Wavelength:	820 nm
Supply voltage:	Included AC power adapters or 12..24 V AC/DC
Current draw:	max. 150 mA at 12 V DC
Isolation:	min. 1 KV between digital-I/O and supply voltage
Temperature range:	Storage: -40..+70°C Operating: 0..+60°C (with external 24V supply)

Housing:	Plastic compact housing for DIN rail mount, dimensions 105x75x22,5mm
Weight:	approx. 750 g incl. power supplies
Scope of delivery:	1 x Digital-I/O Extender Set 2x AC power adapters for office use