

# W&T

[www.WuT.de](http://www.WuT.de)

## Manual

Installation, Startup and Application

### **USB Isolators**

valid for:

#33001 USB-Isolator 1kV

#33204 USB-Isolator 4kV

Release 11/2017

© 11/2017 by Wiesemann & Theis GmbH

Subject to errors and changes:

Since we can make mistakes, none of our statements should be used without checking. Please let us know of any mistakes or misunderstandings you are aware of, so that we can recognize and eliminate them quickly.

Perform work on and with W&T products only as described here and only if you have read and understood the manual fully. Unauthorized use can result in hazards. We are not liable for the consequences of unauthorized use. When in doubt, check with us or consult your dealer!

USB interfaces in stationary computers unfortunately have the basic drawback of having no galvanic isolation for the signal lines.

In many applications in the consumer world this limitation is irrelevant, since the USB devices connected to the PC are generally supplied through the bus and do not have any reference to a second ground or to the ground conductor.

In the areas of measurement reading, process control or for example medical technology, galvanic isolation of the connected devices is mandatory in order to prevent ground loops on the USB line.

Wiesemann & Theis therefore offers USB Isolators which are described on the following pages along with their technical specifications and wiring examples.

For up-to-date information on new developments on the Internet, go to <http://www.wut.de> or the e-mail short infos available from the W&T Interface Club, which you can sign up for at the W&T Homepage.

**Contents**

**Safety instructions ..... 5**

**USB Isolator, 1kV, #33001 ..... 7**

Function .....7

Supply voltage .....7

Display Elements .....8

Speed configuration.....8

Wiring Example.....9

Technical Data .....10

**USB Isolator Industry, 4kV, #33204 ..... 11**

Function .....11

Supply voltage .....11

Isolator output voltage.....12

Display Elements .....12

Speed configuration.....13

Wiring Example.....14

Technical Data .....15

## Safety instructions

### Intended use

The USB Isolators from Wiesemann & Theis provide galvanic isolation of low-speed and full-speed USB connections at different isolation voltages.

The isolators suppress compensation currents which due to potential differences flow between the connected devices and the USB line and which can result in data transmission interruptions or even destroy the interfaces. To prevent this, the isolators are simply inserted into the existing USB line.

**The isolators described in this manual may be used only for protecting USB ports. Use of the isolator to protect persons against contact with hazardous voltages is not permitted. For safety-critical galvanic isolation, please contact us.**



Any other use or modification of the isolators is not permitted.

### Electrical safety

Please ensure that there is sufficient clearance between upstream and downstream cables in order to prevent voltage flashovers between the cables.

If any other than the supplied power supply is used, it must also provide safe isolation of the low-voltage side from the supply network in accordance with EN60950-1. In addition, the third-party power supply must have an LPS feature.

**EMC**

Only shielded signal cables may be used to connect the isolators.

The USB Isolators with then meet the industrial noise immunity limit values and the stricter emissions limits for household and small business applications.

Therefore there are no EMC-related limitations with respect to usability of the isolators.

**Disposal**

The isolators may not be disposed of with household waste, but rather be brought to a proper electronics waste disposal facility.

*A complete Declaration of Conformity for the described isolators can be found on the respective datasheet pages on the W&T Homepage at <http://www.wut.de>.*

**USB Isolator, 1kV, #33001****Function**

The Wiesemann & Theis USB-Isolator #33001 provides galvanic isolation for low-speed and full-speed USB connections with an isolation voltage of at least 1000V DC. The Isolator eliminates ground loops and prevents current from flowing between the connected devices and the supply lines of the USB caused by potential differences. The Isolator is simply inserted into the existing USB connection and powered by an external power supply.

**Supply voltage**

The USB Isolator requires an external power supply for powering the galvanically isolated Isolator side and a bus-powered terminal device.

A suitable wall mount adaptor is included with the Isolator. In principle any 5V DC power supply with a USB output can be used as long as it provides an output current of at least 0.5A.

The supply voltage is brought to the Isolator side through a mini-USB socket. The socket is marked on the Isolator as „Power Connector.“ An appropriate adapter cable for connecting the power supply is also included with the Isolator.

**The USB A plug on the power cable must never be connected to a second USB port on the USB host or hub which is connected to the upstream port of the Isolator. Such a connection would jumper the galvanic isolation and make it ineffective. A galvanically isolated voltage source is therefore absolutely mandatory.**



## Display elements

The Isolator includes two green LEDs for indicating the correct supply voltage for the Isolator. The *Power IN* LED indicates correct power for the upstream side of the Isolator from the USB host or hub, whereas the *Power Out* LED indicates the voltage of the downstream side.

## Speed switching

The USB-Isolator #33001 supports USB devices operating in full-speed mode at 12 MBit/s or low-speed mode at 1,5 MBit/s. Two small switches on the side of the Isolator labeled „Low Speed“ and „Full Speed“ are used to switch between the two speeds.

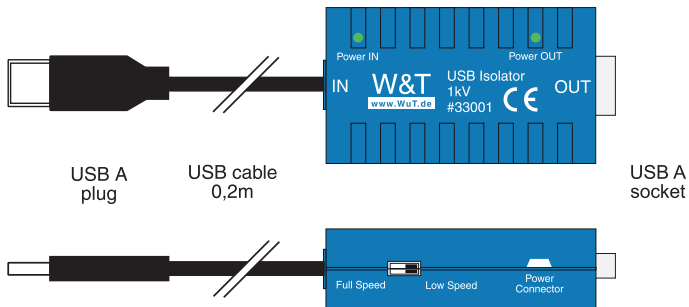

Each switch configures the upstream and downstream side of the Isolator.

**A speed conversion is not possible by the Isolator, so that both switches must always be in the same position. A different setting for both ports will prevent data transmission.**



The factory default setting for the Isolator is Full Speed mode.



**Wiring example**

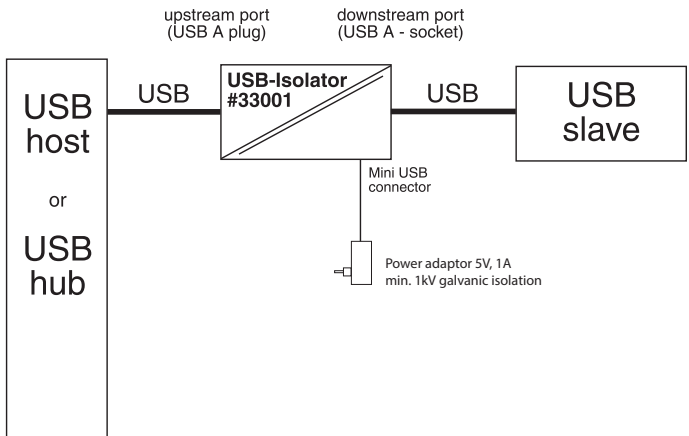

**Technical data**

|                      |  |
|----------------------|--|
| Isolation voltage:   | min. 1 kV DC   |
| Coupling capacitor:  | 10nF   |
| USB speed:           | Full Speed (12MBit/s),<br>Low Speed (1.5 MBit/s)                         |
| Power supply:        |  |
| Upstream-Port:       | USB-supplied   |
| Downstream-Port:     | 5V DC using included<br>power supply                                     |
| Current draw:        |  |
| Upstream-Port:       | max. 8 mA  |
| Downstream-Port:     | max. 8 mA plus<br>current draw of the USB slave                          |
| USB connections:     |  |
| Upstream-Port:       | USB A plug with 20 cm cable  |
| Downstream-Port:     | USB A socket integrated in housing                                       |
| Ambient temperature: |  |
| Isolator:            | Storage: -40..+70°C,<br>Operating: 0..+70°C                              |
| Power supply:        | Storage: -40..+70°C,<br>Operating: 0..+40°C                              |
| Humidity:            | 5..90% relative humidity<br>(non-condensing)                             |
| Housing:             | Plastic compact housing,<br>55 x 30 x 16 mm                              |
| Weight:              | approx. 35 g   |
| Scope of delivery:   | USB Isolator<br>USB power supply 5V / 1A<br>power cable, Mini-USB, 5-pin |

**USB Isolator Industry, 4kV, #33204****Function**

The Wiesemann & Theis USB-Isolator Industry #33204 galvanically isolates low-speed and full-speed USB connections with an isolation voltage of at least 4000V DC. The Isolator thereby prevents unwanted current which could otherwise flow between the connected devices over the data and supply lines of the USB. The Isolator is simply inserted into the existing USB line.

**Power supply**

The USB-Isolator #33204 is generally powered by the USB host and supplies the connected terminal device through an integrated DC-DC converter with power.

Only when connecting bus-powered terminal devices which draw more than 300mA from the USB is use of an additional power supply necessary. Power is then provided via a 5.5/2.1mm plug to the underside of the device housing on the upstream side of the Isolator.

This measure ensures galvanic isolation for all powering options: the terminal device always receives its voltage through the integrated DC-DC converter, which features an isolation voltage of min. 6 kV.

**Important: Virtually any common USB power supply having sufficient power capability can be used to power the Isolator as long as the power cable provided is used. When using a 5V power supply with barrel jack however you must observe its polarity: Outside = „+“, center = „-“. Otherwise the Isolator's internal fuse will be blown.**



## Isolator output voltage

The output voltage  $V_{\text{Bus}}$  from the W&T USB-Isolator 33204 is brought to the galvanically isolated side of the module through a multi-stage L-C filter.

These additional components significantly reduce the noise generated by the integrated DC-DC converter on the supply voltage of the secondary-side USB.

The filtered output voltage means the Isolator is also useful for connecting high-quality audio equipment having a USB port for connecting to a computer.

The maximum output current of the Isolator is 1A.

## Display elements

The Isolator features a pair of LEDs each for the upstream and downstream port, located near the respective connector.

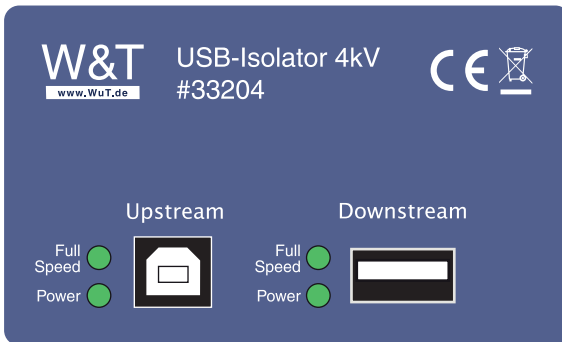

The „Power“ LED of the pair indicates correct supply voltage to the associated Isolator port, whereas the „Full Speed“ LED indicates the set speed of the Isolator.

### Speed configuration

The USB-Isolator #33204 supports USB devices that operate in full speed mode at 12 MBit/s or low speed at 1.5 MBit/s.

Switching between both speed is accomplished by means of two plug-in jumpers located inside the Isolator. One jumper each configures the upstream and downstream side of the Isolator.

If the jumper is plugged into the position labeled „Low Speed“, the corresponding Isolator terminal runs at 1.5 MBit, whereas the port in the other position of the jumper runs at full speed.

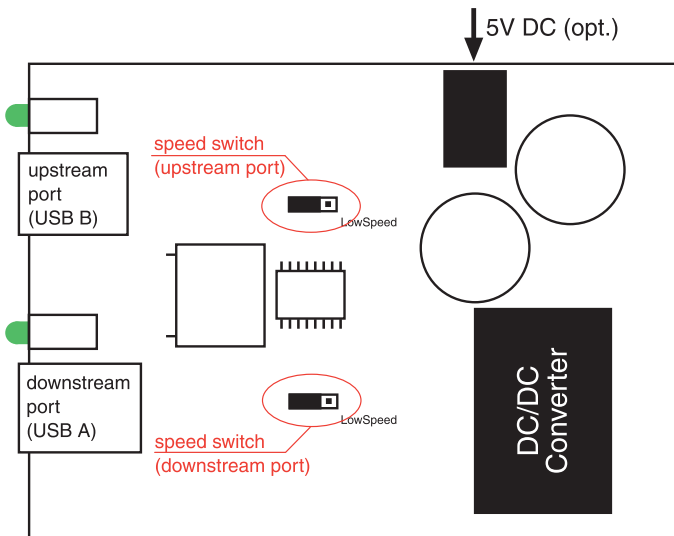

Since low speed devices are uncommon, the USB Isolator model 33204 is factory set to full speed mode.

**A speed conversion is not possible by the Isolator, so that both jumpers must always be in the same position. A different setting for both ports will prevent data transmission.**



**Wiring example**

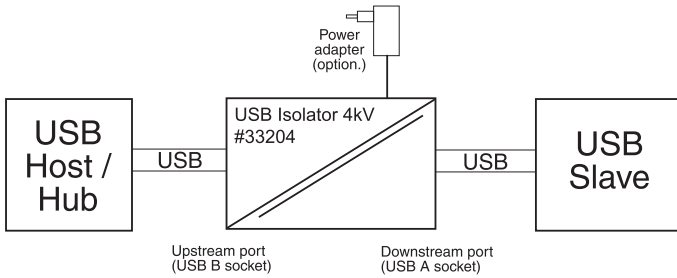

**Technical data**

|                        |   |
|------------------------|---|
| Isolation voltage:     | min. 4kV DC<br>(both for using USB for power<br>and an external power supply)   |
| Air and creepage path: | > 8mm   |
| Coupling capacitor:    | 4,4nF   |
| USB speed:             | Full Speed (12 MBit/s),<br>Low Speed (1.5 MBit/s)   |
| Power supply:          | generally from the USB host over<br>the bus or for high loads from an<br>external 5V power supply                         |
| Max. output current:   | with USB supply: 0,3 A<br>with enclosed power supply: 0,5 A<br>with suitable power supply: 1A                             |
| USB connections:       |   |
| Upstream port:         | USB B socket  |
| Downstream port:       | USB A socket  |
| Ambient temperature:   | Storage: -40..+70°C<br>Operating: 0..+60°C  |
| Humidity:              | 5..90% relative humidity<br>(non-condensing)  |
| Housing:               | Small plastic housing,<br>105x75x45mm   |
| Weight:                | approx. 200 g   |
| Scope of delivery:     | USB Isolator Industry, 4 kV<br>USB cable USB-A / USB-B,<br>USB power supply 5V / 1A with<br>power cable USB-A / coax plug |

Wiesemann & Theis GmbH  
Porschestr. 12  
42279 Wuppertal / Germany

Mail [info@WuT.de](mailto:info@WuT.de)  
Web [www.WuT.de](http://www.WuT.de)

Tel. +49 (0) 202/2680-110  
Fax +49 (0) 202/2680-265