

Manual

Web-Thermometer

Web-Thermo-Hygrometer

Web-Thermo-Hygrobarometer

Web-Thermometer Relay

Web-Thermometer Air Quality



Typ

10/100BaseT, 12-24V

Modell

57707, 57708, 57713,
57714, 57715, 57716,
57718, 57720

Release

1.22, Jun 2018

© 06/2018 by Wiesemann und Theis GmbH
Microsoft, MS-DOS, Windows, Winsock and Visual Basic
are registered trademarks of the Microsoft Corporation

Subject to errors and changes:

Since we can make mistakes, none of our statements should be used without checking. Please let us know of any mistakes or misunderstandings you are aware of, so that we can recognize and eliminate them quickly.

Perform work on and with W&T products only as described here and only if you have read and understood the manual fully. Unauthorized use can result in hazards. We are not liable for the consequences of unauthorized use. When in doubt, check with us or consult your dealer!

Introduction

The W&T Web-Thermometer contains all functions in a box to measure, store and display your climate data. Moreover, the numerous alarm functions are available which can be integrated into your own applications or into available systems.

In this manual you find all information which you need for the installation, configuration and the use of the Web-Thermometer.

Introduction	3
1 Quick-Start/Commissioning	7
1.1 Connecting the sensor (#57713, #57714, #57715, #57718, #57720)	7
1.2 Connecting the PT100/PT1000 sensor (#57708, #57707) and output configuration (#57616).....	8
1.3 Ethernet connection (#57708, #57713, #57714, #57715, #57716, #57718, #57720)	10
1.4 LED-displays	11
2 Supply voltage	15
2.1 Power over Ethernet	15
2.2 External supply.....	15
3.1 Configuring network parameters with WuTility	17
3.1.1 Applications and prerequisites.....	17
3.2 Assigning the IP using DHCP protocol	20
3.2.1 Manual activation of DHCP	20
3.2.2 System name	20
3.2.3 Lease time	21
3.3 Assigning the IP using the ARP command	22
3.4 Assigning the IP using the serial port	24
4 Ethernet interface	26
4.1 Link status.....	26
4.2 10/100BaseT on RJ45	26
5 Connecting the sensor	27
5.1 NTC sensor measuring input (#57714).....	27
5.2 Pt100/1000 sensor measuring input (#57715).....	27
5.3 Combined sensor measuring input (#57713, #57718, #57720)	27

6 Online measurement storage inside the W&T Cloud . 29

6.1 Auto connect	29
6.2 Create a user account	29
6.3 Assign data by 4-digit access code in the cloud	30
6.4 Assign measured data via user account in the device	30

7 Configuration Using Web-Based Management 31

7.1 Home.....	31
7.2 Visualization.....	32
7.3 Own webpage	33
7.4 Login	33

8 Basic Settings..... 35

8.1 Network.....	35
8.2 Sensors.....	36
8.3 Date/Time	36
8.4 Language/Infos.....	36
8.5 Data storage	37
8.6 Password	37

9 Web sites 38

9.1 Browser access	38
9.2 Home.....	38
9.3 My Web page	38

10 Communication paths 41

10.1 Mail	42
10.2 MQTT	42
10.3 REST	43
10.4 Cloud.....	46
10.5 Web-API	46
10.6 Socket-API.....	47
10.7 RSS	47
10.8 SNMP/Syslog.....	47
10.9 FTP	48

11 Alarms/Messages 49

12 Diagnosis 51

13 Device information 52

14 Maintenance..... 53

14.2 Factory defaults53

14.3 Save configuration53

14.4 Restore configuration53

15 Individual request of measurement values..... 54

15.1 Request via TCP/IP Socket API54

15.2 Requesting via UDP Socket API55

15.3 Requesting via SNMP.....56

16 Firmware Update..... 59

16.1 Where is the latest firmware available?59

16.2 Firmware update over the network under Windows59

17 Hardware-Reset to factory defaults 61

18 Technical data..... 63

18.1 Technical data for the articles 57714 and 5771563

18.2 Technical data for the articles 57713 and 5772064

18.3 Technical data for the article 57716.....65

18.4 Technical data for the article 57718.....66

18.5 Technical data for the article 57707.....67

18.6 Technical data for the article 57708.....68

19 Disposal..... 69

1 Quick-Start/Commissioning

Just a few steps are required to start up your W&T Web-Thermometer and to make it visible in your network.

Power-over-Ethernet

The Web-Thermometers are designed for use in PoE (Power-over-Ethernet) environments in accordance with IEEE802.3af. Power is provided by the network infrastructure using the RJ45 terminal. The devices support both phantom power using data pairs as well as power feed using the unused wire pairs s. *Power Supply*).

! Use of the Web-Thermometer is also possible in networks without PoE power supply. In this case simply use an external power supply attached to the screw terminal as described in the chapter *Power Supply*. No additional configurations or settings are necessary.

1.1 Connecting the sensor (#57713, #57714, #57715, #57718, #57720)

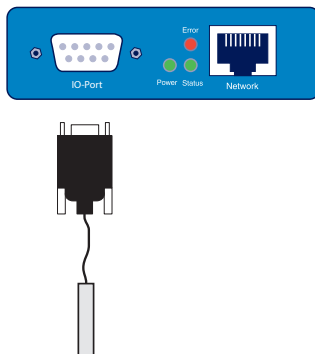

Plug the sensor included in the scope of delivery into the 9-pin IO terminal on the unit.

Information for Web-Thermometer Air Quality, #57718:

! The measuring of the VOC value begins after an initialization time of 15 minutes after powering on the device. In this time a VOC value of 450ppm will be displayed while the sensor is calibrated to the current room air quality. Therefore, make sure that the room in which the sensor is positioned is well-ventilated at this time so that the sensor can measure a good room air quality as a reference.

1.2 Connecting the PT100/PT1000 sensor (#57708, #57707) and output configuration (#57616)

#57708 Web-Thermometer 8x:

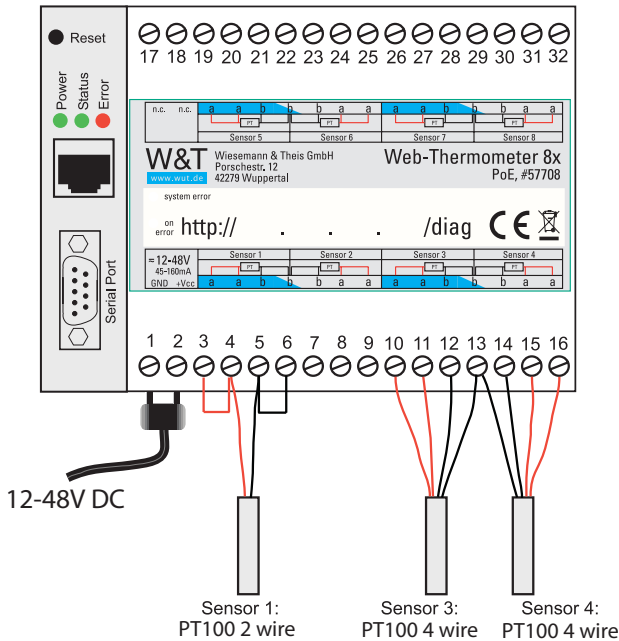

#57707 Web-Thermometer 2x:

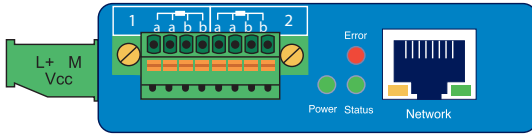

PT100 4-wire

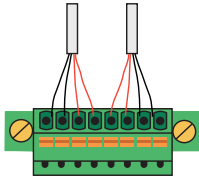

#57616 Web-Thermometer Relais:

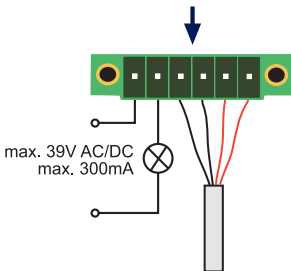
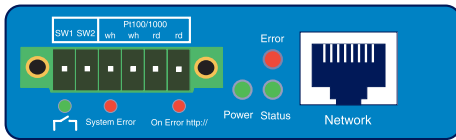

The output of the Web-Thermograph Relay is switched internally using a relay contact (normally open). The consumer is connected to the screw terminals 1 and 2. The maximum switchable DC or AC voltage is 39V, with a maximum current flow of 300mA.

The PT100 or PT1000 temperature sensor is connected to screw terminals 3, 4, 5 and 6, whereby the wires of the same color must lie adjacent to each other.

The incoming line to the PT100 4-wire sensor may be of vir-

W&T

tually any practical length.

Connecting a PT100 3-wire sensor:

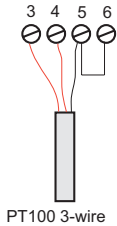

When connecting a PT100 3-wire sensor the same-color wires are connected to the terminals marked with the corresponding colors. A jumper to the remaining free terminal is required for the single wire.

Connecting a PT100 2-wire sensor:

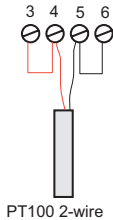

When connecting a PT100 2-wire sensor, one wire is brought to the red terminal and the other to the black terminal. Jumpers must be placed here to the free terminals.

1.3 Ethernet connection (#57708, #57713, #57714, #57715, #57716, #57718, #57720)

The Web-Thermometer incorporates an IEEE802.3-compatible network interface on a shielded RJ45 connector. The pin assignments correspond to an MDI port, so that the connection to the hub or switch is accomplished using a 1:1 shielded patch cable.

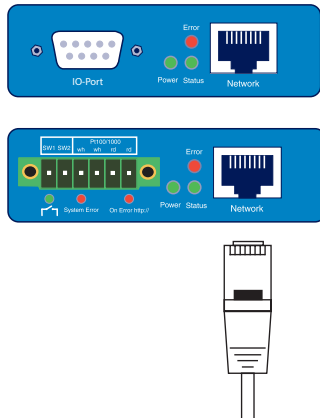

1.4 LED-displays

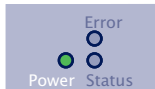

Power-LED

OFF: There is no power present. Check the correct connection of the supply (PoE or the external power supply)

ON: Power is present (PoE or the external power supply).

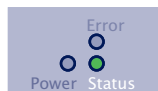

Status-LED

Rapid continuous flashing = bootup, no IP

Rapid continuous flashing (approx. 3x/s) indicates that the device is in the bootup phase and/or has not yet been assigned an IP address. Please use WuTility for example to assign the device an IP address.

Slow continuous flashing = connection

Periodic flashing indicates that the port has a valid connection to another network station. After the IP configuration you can open the homepage of the device with a web browser.

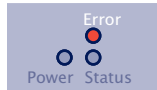

Error-LED

The Error-LED shows errors of the device.

All LEDs on = Self-test error

The self-test performed after each start or reset of the device could not be correctly finished. This error can occur when you have prematurely broken off a software update and the full operating software could not be transferred. The device is no longer capable of being operated in this condition. Repeat the software update over the network (see *Firmware update*), and address the device using its assigned IP address. If this does not eliminate the error or should the error occur irrespective of any prior software update, please return the unit to W&T for service.



Speed (yellow)

OFF: Simultaneous illumination/flashing of the Link/Activity LED means there is a link to a device at a rate of 10 MBit/s (10BaseT).

ON: Simultaneous illumination/flashing of the Link/Activity LED means there is a link to a device at a rate of 100 MBit/s (100BaseT).



Link/Activity (green)

OFF: The device is not detecting a Link pulse from a hub or switch. Check the cable or the hub port.

W&T

ON: The device has a valid link to a hub or switch. The Speed LED indicates the data rate in this case.

Flashing: The device is receiving or sending network packets.

Additional LEDs (internal: #57713, #57714, #57715, #57718, 57720, external: #57716)

- ➔ on error <http://xxx.xxx.xxx.xxx/diag> -LED: Indicates internal configuration errors. For troubleshooting, please open the page <http://xxx.xxx.xxx.xxx/diag> in the device.
- ➔ system error: Serious hardware error. Attempt to start the device up again by interrupting supply voltage. If the condition persists, please return the unit for inspection.



If the Web-Thermometer has no IP address or Address 0.0.0.0, the on error and system error LEDs remain on! The system error LED flashes 3x after a brief time. The LEDs do not turn off until an IP address has been assigned.

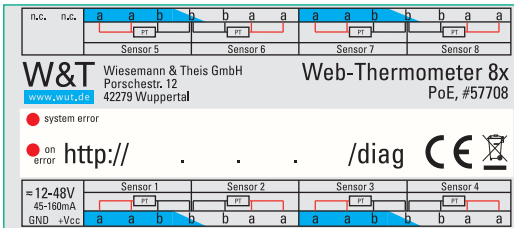
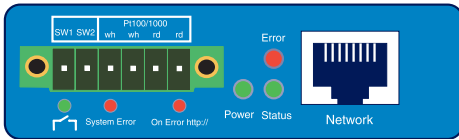
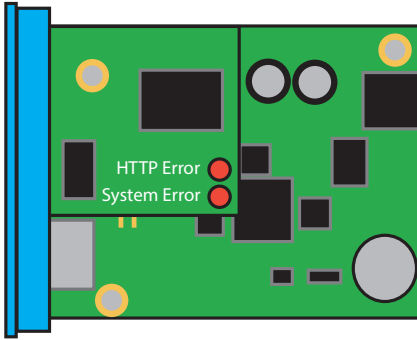

2 Supply voltage

The Web-Thermometer can also be operated either using PoE or from an external power supply.



Connecting an external supply voltage and a PoE infrastructure at the same time is not permitted.

The current draw can be found in the technical appendix.

2.1 Power over Ethernet

In PoE environments (Power-over-Ethernet, IEEE802.3af) power is provided by the network infrastructure. The device supports both phantom power using data pairs 1/2 and 3/6 as well as power feed using the unused wire pairs 4/5 and 7/8.

The Web-Thermometer is a device in PoE Power Class 1 (power consumption 0.44 to 3.84W).

2.2 External supply

As an alternative to PoE power supply the device can also be powered by an external power supply connected to the screw terminals on the underside of the housing. A half-wave rectifier makes the input reverse polarity protected. AC or DC power may be used, whereby the following limit values must be observed:

- AC: 18V_{eff} (- 10%) - 30V_{eff} (+10%)
- DC: 12V (-10%) - 48V (+10%)

When powering with DC voltage polarity must be observed:

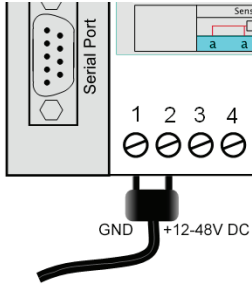
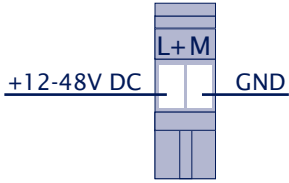

3.1 Configuring network parameters with WuTility

WuTility is the central inventorying and management tool for all W&T network devices. In addition to convenient assigning of the IP parameters, *WuTility* also provides quick access to device configurations, the ability to perform firmware updates, managing configuration profiles, etc.

WuTility can be directly installed from the included product CD. Current versions are always available on our website at <http://www.wut.de>. From there you can navigate using the menu tree on the left side.

Downloads → *Web-Graph* → *Software-Tools*

After extracting the ZIP file you install *WuTility* by double-clicking on the file *wutility_***.msi*. Start WuTility using

Start → *All Programs* → *W&T Software Toolkit* → *WuTility*

3.1.1 Applications and prerequisites

IP assignment using WuTility works regardless of the current network parameters of the device and the computer used. This means that even if the device does not have IP parameters consistent with the respective network, WuTility can be used to overwrite them. Likewise, WuTility can be used to assign any values not consistent with the network the PC is located in.

- The PC and device must be located in the same physical network. This means you cannot assign values through a router.
- Any firewalls and network security packages installed on the PC must allow communication between WuTility and the device based on UDP broadcasts. If necessary these must be correspondingly configured or temporarily turned off.

- If the device does not have its factory default settings and there is a system password assigned, this must be known in order to make changes using WuTility.

Step 1: Start the assignment dialog

WuTility automatically searches the local network for connected W&T network devices and creates an inventory list. This search process can be repeated manually as often as desired by clicking on the Scan button:



Within the inventory list you can identify the desired device based on its MAC address. For initial installations its IP address is 0.0.0.0.

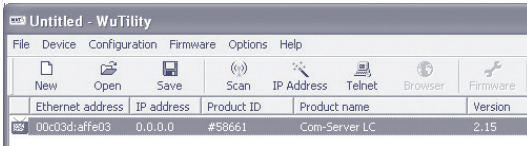

Select the device and click on the *IP address* button:



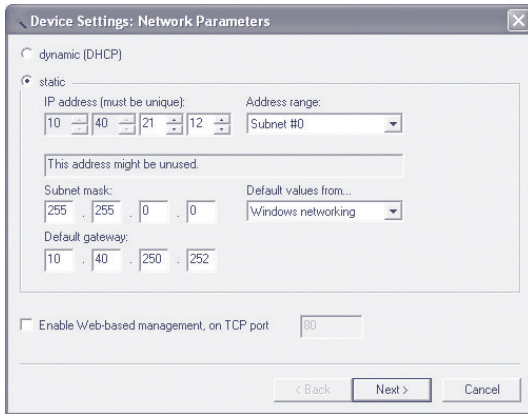

Step 2: Assign the IP parameters

The *Static* option allows you to assign fixed basic parameters while simultaneously disabling the *DHCP* protocol in the device. Enter the desired values for IP address, subnet mask and gateway address in the corresponding entry fields. The *DHCP* option enables DHCP protocol in the device, and operation with a static IP address is no longer possible (see *IP Assignment using DHCP Protocol* for detailed information).

Clicking on the *Next* button assigns the network parameters to the device. After acknowledging the resulting message, all the columns in the *WuTility* device list are filled in with information.

If necessary, the remaining configuration of the device is done using Web-Based-Management. Click on the Browser button.

Browser:



Additional information can be found in the section *Configuration Accesses for the Web-Thermometer*.

3.2 Assigning the IP using DHCP protocol

DHCP protocol is activated by the factory default settings, so that in network environments dynamic IP assignment is sufficient for connecting the device to the network. The following parameters can be assigned using DHCP:

- IP address
- Subnet mask
- Gateway address
- DNS-Server

3.2.1 Manual activation of DHCP

To prevent unintended address assignments or address changes, DHCP protocol is automatically deactivated when using all other methods for assigning the IP parameters. The following methods are then available for later activation of DHCP.

- **Management-Tool WuTility**
Select the desired device from the device list and click on the IP Address button. In the following dialog check the option DHCP and then click on Next.
- **WBM configuration**
In the menu branch *Basic settings* → *Network* → *TCP/IP Settings* you can activate DHCP protocol.



A set static IP address is deleted after DHCP is activated and the associated automatic reset. The device automatically sets this to 0.0.0.0 and starts sending DHCP requests.

3.2.2 System name

To support any automatic updating of the DNS system by the DHCP server, the device identifies itself within the DHCP protocol with its system name. The factory default setting for this is *WEBIO-* followed by the last three places of the Ethernet address. For example the factory set system name of

a device with the Ethernet address 00:c0:3d:01:02:03 is *WE-BIO-010203*. The system name of the device can be changed in the configuration. For additional information refer to the section *Menu: Basic Settings → Language/Infos*.

3.2.3 Lease time

The lease time determined and transmitted by the DHCP server specifies the Time-To-Live of the assigned IP address. After half the lease time has expired, the device attempts to extend the time for the assigned DHCP server and update the address. If this is not possible by the time the lease time expires, for example because the DHCP server can no longer be reached, the device deletes the IP address and starts a new cyclical search for alternate DHCP servers for the purpose of assigning a new IP address.

Because of the absent clock, the lease time associated with the current IP address is no longer available after a reset. After the restart therefore a corresponding update request is issued with the original DHCP server. If the latter is not resolvable at this point in time, the device deletes the IP address and starts a new cyclical search for alternate DHCP servers.

If DHCP is activated, the remaining lease time together with the current IP address is displayed in the menu item *device Information* using the format hh:mm:ss.

3.3 Assigning the IP using the ARP command

Requirements

This method can only be used if the device does not already have an IP address, i.e. the entry is 0.0.0.0. To change an IP address, use one of the other methods described in this section or use the configuration menu over web based management. If the device has any other value, this access is disabled.

When the factory setting is in effect as well as after a manual changeover from static to DHCP, the method for assigning the IP described in this section functions only after a delay of approx. 2 minutes after a reset or after power-up.

This method does *not* work across networks, e.g. through routers. This means the PC and device used for assigning must be connected to the same physical network segment. Only IP addresses whose Net-ID is identical to that of the assigning computer can be assigned.



To avoid unintended changes to the IP address, the DHCP client of the Com-Server is automatically deactivated when configuring using a static ARP entry.

Step 1

Read off the Ethernet address of the device from the sticker on the side of the housing.

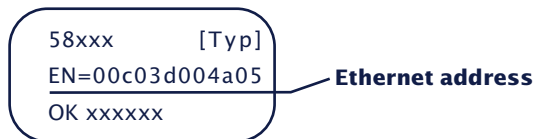

Insert a static entry into the ARP table of the computer using the following command line:

```
arp -s [IP address] [Ethernet address]
```

E.g. under Windows:

```
arp -s 172.16.231.10 00-C0-3D-00-12-FF
```

E.g. under UNIX/Linux:

```
arp -s 172.16.231.10 00:C0:3D:00:12:FF
```

 *The IP addresses must be without leading zeros in all Windows environments. Otherwise the entry is incorrectly interpreted by the system and an incorrect IP address is assigned to the device. In Windows Vista and newer the prompt cmd.exe necessary for invoking the ARP command must be started using Administrator rights.*

Step 2

Use the following command line to *ping* the device with the desired IP address:

```
ping 10.40.21.12
```

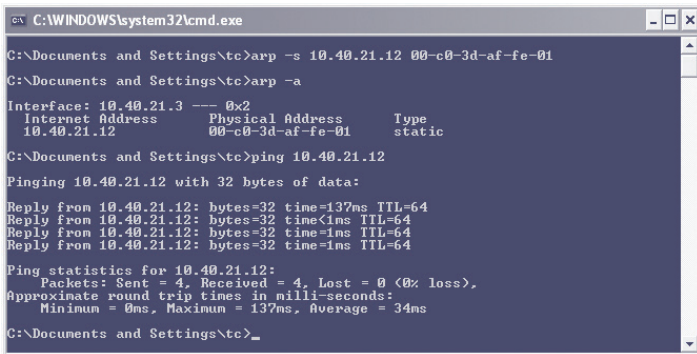

```
C:\WINDOWS\system32\cmd.exe
C:\Documents and Settings\etc>arp -s 10.40.21.12 00-c0-3d-af-fe-01
C:\Documents and Settings\etc>arp -a
Interface: 10.40.21.3 --- 0x2
   Internet Address      Physical Address      Type
   10.40.21.12           00-c0-3d-af-fe-01    static
C:\Documents and Settings\etc>ping 10.40.21.12
Pinging 10.40.21.12 with 32 bytes of data:
Reply from 10.40.21.12: bytes=32 time=137ms TTL=64
Reply from 10.40.21.12: bytes=32 time<1ms TTL=64
Reply from 10.40.21.12: bytes=32 time=1ms TTL=64
Reply from 10.40.21.12: bytes=32 time=1ms TTL=64
Ping statistics for 10.40.21.12:
    Packets: Sent = 4, Received = 4, Lost = 0 (0% loss),
    Approximate round trip times in milli-seconds:
        Minimum = 0ms, Maximum = 137ms, Average = 34ms
C:\Documents and Settings\etc>_
```

The device takes the IP address of the first network packet sent to it as its own and saves it in non-volatile memory. The ping requests of the PC are then replied.

It is not possible to configure the subnet mask and gateway address using a static ARP entry. These need to be set in a separate Telnet configuration session (see section *Basic Configuration of the device*).

3.4 Assigning the IP using the serial port

Only works for the devices **57708, 57713, 57714, 57715, 57720**.

After a device reset a time window of around 1-2 seconds is available, during which you can assign a new IP address, subnet mask and gateway address by entering at least 3 „x“.

In contrast to other methods described above, this serial method functions regardless of whether the device already has an IP address, a password or not. The procedure can be repeated as often as desired.



To avoid unintended changes to the IP address, the DHCP client of the device is automatically deactivated when configuring using the serial port.

Preparations/requirements

First connect the serial port A of the device to a computer. For a standard PC or laptop, you will need a *crossed* RS232 cable where only the pins 2,3, and 5 are connected.

Any serial terminal program can be used for assigning. The following transmission parameters must be set regardless of any other settings in the device:

9600 baud, no parity, 8 data bits, 1 Stop bit, no Handshake

Start the serial configuration mode

Reset the device by interrupting the power. While the device is starting up, use the terminal program to send the letter x at least three times. The device will then return the prompt *IPno.+<Enter>:*.

Assigning the IP settings

Use the usual format (xxx.xxx.xxx.xxx) to enter the IP address, and end the entry by pressing *<Enter>*. If the entry was accepted, the acknowledgement is the assigned IP address. Otherwise you will get a *FAIL* message followed by the last current IP address.

W&T

Together with the IP address, the subnet mask and gateway address can also be assigned serially. The entry is separated by commas and follows the IP address. Entering as shown in the following example will assign IP address 172.17.231.99, subnet mask 255.255.255.0 and gateway 172.17.231.52 to the device.

Exampel: Assigning the IP address:

```
IP no.+<ENTER>:                <- Web-Thermometer
172.17.231.99                    -> Web-Thermometer
```

Example: Assigning IP address, Subnet mask and gateway

```
IP no.+<ENTER>:                <- Web-Thermometer
172.17.231.99, 255.255.255.0,172.17.231.1 -> Web-Thermometer
```

4 Ethernet interface

The Web-Thermometer incorporates an IEEE 802.3-compatible network interface.

4.1 Link status

The Link status is indicated on the two LEDs built into the RJ45 jack.

- **Link/Activity (green)**
ON indicates a valid link to a hub or switch port. The LED flashes when there is data traffic.
- **Speed (yellow)**
ON indicates a 100MBit/s-link (100BaseT). OFF indicates 10MBit/s (10BaseT)

4.2 10/100BaseT on RJ45

The Web-Thermometer has a 10/100BaseT network interface on a shielded RJ45 connector. The pin assignments shown below correspond to an MDI interface, so that the connection to the hub or switch is made using a max. 100m long 1:1 shielded patch cable.

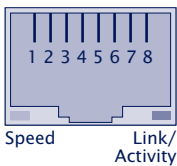

The network connection is galvanically isolated with respect to the supply voltage as well as the serial interface(s) for at least $1,5\text{kV}_{\text{rms}}$.

Auto Negotiation: 10/100BaseT, Full/Half Duplex

The device is factory set to operate in Auto-Negotiation mode on the network side. The data transmission speed and duplex are automatically negotiated with the connected switch/hub and set accordingly.

5 Connecting the sensor

5.1 NTC sensor measuring input (#57714)

The cable of the sensor is not extendable. Please, use exclusively the added sensor.

5.2 Pt100/1000 sensor measuring input (#57715)

The supply line of the measuring sensor can be extended almost in any length. If an extension is desired, it is recommended to use well-shielded cables to prevent interference. If you want to connect an alternative PT100/PT1000 sensor or extend the supply line, the pin assignment is as follows:

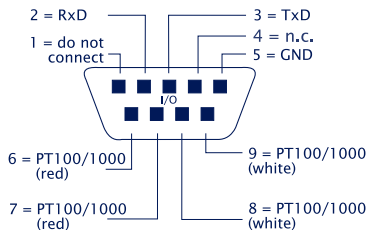

5.3 Combined sensor measuring input (#57713, #57718, #57720)

The provided sensor uses a digital measuring value transfer. A lengthening is possible up to a total length of 20 m (2 m of sensor cable + 18 m of lengthening).

We recommend a DB9 plug connector for a connection to the provided sensor for the lengthening.

We recommend the use of a data cable with the least specification Cat. 5 (shielded) or better and the following pin allocation:

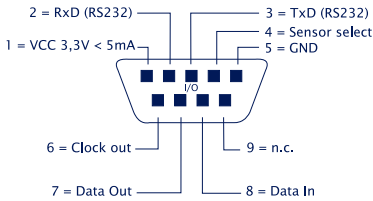
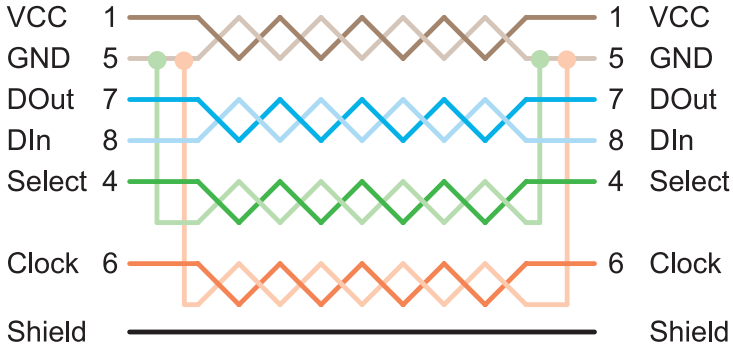

6 Online measurement storage inside the W&T Cloud

With the cloud service W&T offers a comprehensive solution that enables the backup of data in online storage in addition to the long-term documentation of temperature and humidity measurement data in the internal data logger. The measurement data will be sent directly from the measuring point to the cloud, and is available online.

6.1 Auto connect

The cloud functionality is enabled by default on delivery. If the device receives its network parameters via DHCP, or you allow the device Internet access by entering the network parameters, it immediately begins the transmission of the collected values in the cloud.

The measuring data is first not assigned to a user account and will be stored in an enclosed part of the cloud until further use.

6.2 Create a user account

To personalize the measurement data, first a user account for the cloud access must be created. To do this, go to the cloud homepage

<http://cloud.wut.de>

and click on „create user account“.

After entering your e-mail address and a password you will get access to the cloud.

6.3 Assign data by 4-digit access code in the cloud

Log in with your user account to <http://cloud.wut.de> and enter the access code included with the device. The collected data are now associated with your account and are available for you immediately.

Alternative:

6.4 Assign measured data via user account in the device

After you have created a cloud user account, open the configuration menu of your device and login as admin user. Navigate to the page

Communication Paths -> Cloud

and enter your user data for the cloud access. After clicking on the button „Bind“ all measurement data of this device, from this moment, is stored into your user account.

By clicking on the button „Unbind“ the allocation of the data from this moment is separated and no further values will be stored in your account.

Click again on „Bind“ and a new series of measurements is created in the cloud for your user account that contains all the unassigned values of the sensor.



For further information about the service of the Cloud functions you find instructions on <http://cloud.wut.de>

7 Configuration Using Web-Based Management

The remaining configuration is done using the web page of the device. To open this, enter the assigned IP address in the address line of your web browser:

http://<IP-adresse>

7.1 Home



The following pages are also available:

7.2 Visualization

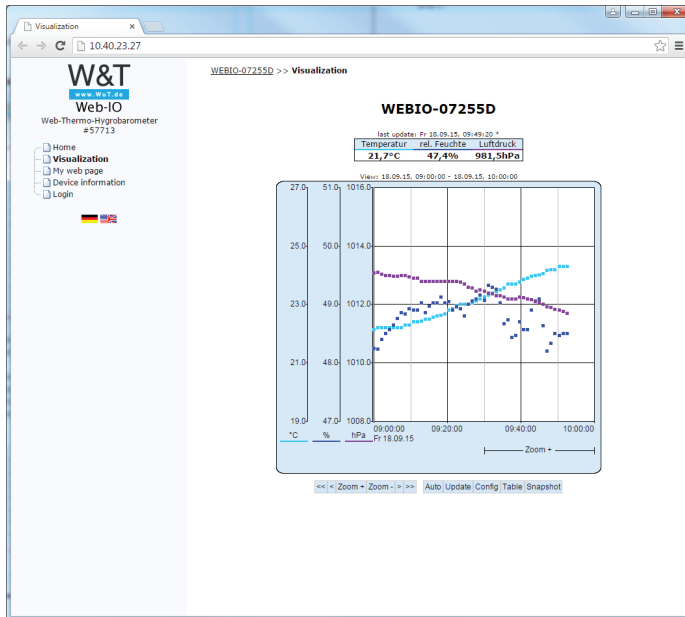

This page shows you a graphical display of the stored measurement values.

The displayed control elements enable you to adapt this display temporarily, as long as you are on this page. A non-temporary change can be made from the configuration menu (s. *Web sites >> Home*).

7.3 Own webpage

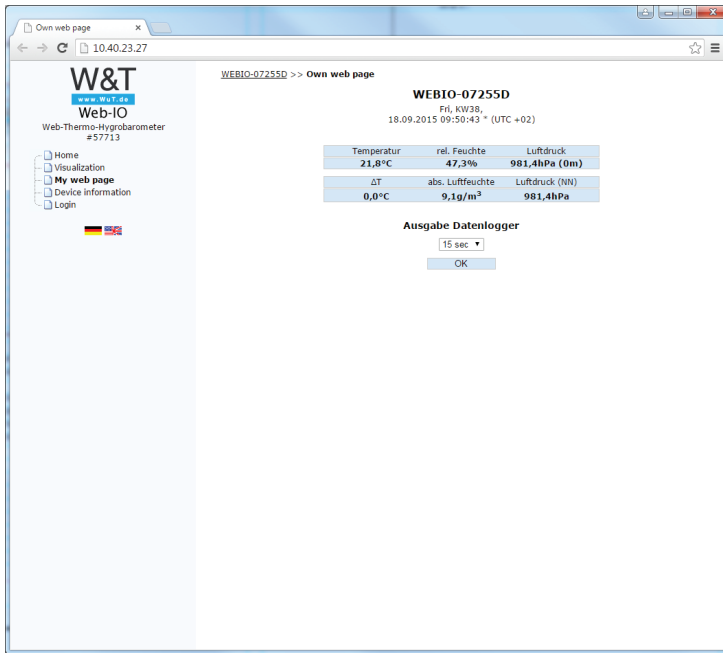

This page can be individually adjusted or replaced and serves as an example. Here you are also able to take a look at the data logger of the device.

7.4 Login

[WEBIO-07255D](#) >> [Login](#)

Login

The login form is titled 'Login' and contains the following fields and options:

- User: Administrator User
- Password:

Login

W&T

The Login dialog gives you access to the device configuration. The device differentiates between an administrator and a standard user with different access rights.

As shipped the device has no password configured. Select the administrator or user and click on "Login".

The menu tree with all the configuration parameters is now shown.

To get additional information about the respective configuration parameter, click on the Info button on the right border of the corresponding parameter.



8 Basic Settings

This configuration area is where you make all the settings needed for the various operating modes.

WEBIQ-078349 >> **Basic-Settings**

Basic-Settings

Here you are able to set the basic configuration.

Network	Set the network basic parameters here.
Sensors	Here you will find all the sensor settings. For example, you can configure the name that appears, specify units, or adjust the measured value if necessary.
Date/time	The device time is necessary to create a time stamp for data storage of the measured values. Enter the time of day manually or use the convenience of automatic time compensation using a time server.
Language/infos	Select here the device language and enter additional device information such as its location or contact information. You may also upload your own logo.
Data storage	Select which sensors should be stored and configure the storage interval. The default interval is 15 seconds. Note that changing these settings results in a memory deletion.
Password	You may optionally set password protection for access to the configuration. You can set a password for an administrator user and for a standard user. The standard user has no access right to device system settings such as changing network parameters, etc.

8.1 Network

Here is where you set the network basic parameters. You can choose between automatic address assignment per DHCP or manual configuration of the parameters. If you wish to configure communication parameters with names instead of IP addresses in the further configuration, you can configure additional DNS servers here in addition to any DNS server which is assigned via DHCP.

HTTP or HTTPS

The default HTTP configuration for browser access is port 80. To change access to HTTPS or change the port, select *Basic-Settings » Network* in the navigation tree, and then select

Protocol in Access for web services. All other settings relating to the display in the browser can be made under web pages.

Setting the system ports and maintenance accesses

The ports activated here facilitate maintenance and configuration. To meet specific security requirements, the ports could be disabled.

8.2 Sensors

Here among other things you are able to configure the labels for the sensors and, for temperature sensors, the units.

If you want to make an adjustment to the sensors, you can choose between 1-point compensation, whereby a correction value is added to or subtracted from the measurement value, or 2-point compensation, in which a straight line is calculated over the measuring range

8.3 Date/Time

The device time is necessary for obtaining plausible time stamps for storing the measurement values.

Enter the time manually or use the convenience of the automatic time-of-day compensation using a time server.

Here you can also enable or disable the use of daylight savings time.

8.4 Language/Infos

Here you configure the standard language of the device. This is automatically used when device pages are opened. The standard language can be dynamically switched during operation using the flags below the configuration menu. This switch is temporary and not saved.

W&T

On this page you can change information and device labels and upload an individual logo, which is displayed above the configuration menu.

8.5 Data storage

Configure at what time interval the measurement data should be saved in the internal data logger and which sensors should be included.



A change to these settings will clear the entire data logger and the measurement recording will begin over again.

In addition, you can download the contents of the data logger as a CSV file for further processing. On this page you can also clear the data logger.

8.6 Password

Set up optional password protection for access to the configuration.

You can set a password for an administrator-user and for an operator-user.

The operator-user has no access rights to system settings for the device, such as changing network parameters etc.



If you assign an administrator password, it must be stored for IP address changes via WuTility or firmware updates.

9 Web sites

This device has three preset pages which can be selected as the start page.

The default homepage shows you the current values of the individual sensors, which are updated cyclically.

The visualization page makes it possible to represent the measurement values graphically.

9.1 Browser access

Here you have the option to deactivate browser access and select the start page.



Note that if you disable browser access, you will not be able to configure any more over the web interface. In order to reactivate this, you must first reset the device to factory settings using the jumper.

9.2 Home

Here you can customize the appearance and access rights of the home page.

9.3 My Web page

The user page can be individually designed. To do this it can be downloaded from the device, edited by you and again uploaded.

To display the measurement values on the user.htm page you can use the following tags in the source text, which are replaced with the corresponding values when the page is opened:

```
<w&t_tags=t1>
```

Shows the current temperature (°C) of the first temperature

W&T

sensor. When multiple sensors are used this index is numbered in sequence.

`<w&t_tags=h1>`

Shows the current relative humidity (%) for models 57713 and 57720.

`<w&t_tags=ah>`

Shows the current absolute humidity (g/m³) for models 57713 and 57720.

`<w&t_tags=pa>`

Shows the absolute air pressure (hPa) for model 57713.

`<w&t_tags=pNN>`

Shows the calculated air pressure (hPa) above sea level for model 57713 (meteorological value).

`<w&t_tags=a1>`

Shows the set altitude of the location of the device for model 57713. (m)

`<w&t_tags=time>`

Inserts the current time of day.

Background color:

For values shown in tables you use corresponding background colors depending on the sensor state:

`<w&t_tag=bct>`

Describes a background color (BGColor), which depends on the alarm status of the temperature sensor. If a limit has been violated, this color is red. Otherwise the tag does not describe any explicit color. This tag is necessary for example for showing limit violations in red in the log table. (°C)

`<w&t_tag=bch>`

Background color for the relative humidity value

`<w&t_tag=bcah>`

Background color for the absolute humidity value

W&T

```
<w&t_tag=bcrc>
```

Background color for the current rate of change

```
<w&t_tags=sensorx>
```

Inserts the name of sensor x in the page.

```
<w&t_tags=device_name>
```

Inserts the assigned device name.

```
<w&t_tags=device_text>
```

Inserts the freely configurable, descriptive text for the device.

```
<w&t_tags=location>
```

```
<w&t_tags=contact>
```

Inserts the respective text blocks which can be configured under Language/Infos.

This page also provides all the parameters needed for adjusting the visualization.

10 Communication paths

This device can communicate over various network protocols and services. Here you configure all the parameters necessary for this.

[WEBIO-078349](#) >> **Communication paths**

Communication paths

Here you will find the settings for the network services used for enabling the device to communicate.

Mail	The e-mail function allows you to forward messages to one or more recipients. Here you configure the access parameters for your mail server. SSL/TLS encrypted connections are usual.
MQTT	The Web-Thermometer can send the measured values to an MQTT broker when there is a change or cyclically via MQTT as a topic.
REST	The measured values as well as the device status can be queried using REST (Representational State Transfer). In the Rest query you specify whether the reply should be in JSON or XML format or as a raw text.
Cloud	With the cloud service W&T offers a comprehensive solution that enables the backup of data in online storage in addition to the long-term documentation of temperature and humidity measurement data in the internal data logger. The measurement data will be sent directly from the measuring point to the cloud, and is available online.
Web API	Here you specify whether access is permitted to device status and measurement values via HTTP requests (e.g. for dynamic websites that use AJAX but also to give third-party equipment such as web cameras access to the measurement values).
RSS	The device provides an RSS feed that feed readers can subscribe to. Here you can configure the necessary channel settings.
SNMP	Make the SNMP basic settings here. The device can be incorporated into your existing automation system via SNMP. Use corresponding OIDs to query device and sensor data, or send messages via SNMP trap. An MIB can be downloaded directly in the device at <a href="http://<ip-adresse/mib.zip">http://<ip-adresse/mib.zip .
Syslog	Make the syslog basic settings here. The device can be incorporated into your existing automation system via syslog.
FTP	Messages can be stored directly on an FTP server for archiving and control. Here you configure the basic settings of the FTP client.
Socket API	You can directly retrieve the measured data on a socket access from the device. In the simplest case, send the command "GET /Single" to the unit to get back the current measurement data from the device. The ASCII modes use readable GET commands based on HTTP protocol.

W&T

10.1 Mail

The e-mail function allows you to send messages to one or more e-mail recipients. Here you configure the access parameters for your mail server.

10.2 MQTT

After activation of MQTT and configuration in the menu branch *Communication Paths » MQTT*, the Web-Thermometer supports the following:

Transfer of the individual measured values as an MQTT topic to an MQTT broker via MQTT-Publish.

This function is managed as an alarm / message in the Web-Thermometer. A detailed description of the action philosophy used in the device can be found in the section **Alarms/Messages**.

Publish of measured values

To create a new MQTT-Publish, click the *Add* button under *Alarms/Messages*. The input mask for a new message appears.

Here you can determine which name the message has and what the trigger should be.

Determine e.g. as the trigger the temperature sensor.

Select MQTT-Publish as the action. In the following menu, enter the path to which the topic is to be written to the broker.

You can freely determine the textual content of the topic, whereby the placeholders described in the infotext can be

W&T

used.

10.3 REST

With REST (Representational State Transfer), the Web-Thermometer provides a further web-based communication path.

Communication takes place via specific HTTP requests via the HTTP or HTTPS port entered under *Basic settings » Network » Access for web services*.

To be able to exchange data via REST, the access must first be activated via *Communication paths » REST*.

If the REST access should be protected against unauthorized access, you have the option to enable Digest-Authentication. The requests should then be made as user „Admin“ with the administrator password or as user „User“ with the user password.

Read access

For read accesses, REST uses the HTTP command GET.

The Web-Thermometer supports three formats for answers to REST requests:

- JSON
- XML
- Text

In what format is answered, can be determined about the request. With

```
http://<ip-address>/rest/json
```

e.g. the entire process image of the Web-Thermometer can be retrieved in JSON format. The answer then looks like this:

```
{
  „info“: {
    „request“: „/rest/json“,
    „time“: „2017-02-02,10:21:06“,
    „ip“: „10.40.23.17“,
    „devicename“: „WEBIO-078349“
  },
  „iostate“: {
    „sensor“: [{
      „name“: „Temperatur“,
      „number“: 0,
      „unit“: „°C“,
      „value“: 22.2
    }, {
      „name“: „rel. Feuchte“,
      „number“: 1,
      „unit“: „%“,
      „value“: 32.4
    }, {
      „name“: „Luftdruck“,
      „number“: 2,
      „unit“: „hPa“,
      „value“: 988.7
    }
  ]
},
  „system“: {
    „time“: „2017-02-02,10:21:06“,
    „diagnosis“: [{
      „time“: „08.02.2017 10:21:06“,
      „msg“: „Device status: OK“
    }],
    „diagarchive“: [{
      „time“: „08.02.2017 10:21:06“,
      „msg“: „Device status: OK“
    }
  ]
}
```

```
}  
}
```

In order to query only individual areas or points, the request can be formulated in more detail:

```
http://<ip-adresse>/rest/json/iostate
```

This causes the Web-Thermometer to return the status of all sensors:

```
{  
  „iostate“: {  
    „sensor“: [{  
      „name“: „Temperatur“,  
      „number“: 0,  
      „unit“: „°C“,  
      „value“: 22.4  
    }, {  
      „name“: „rel. Feuchte“,  
      „number“: 1,  
      „unit“: „%“,  
      „value“: 32.3  
    }, {  
      „name“: „Luftdruck“,  
      „number“: 2,  
      „unit“: „hPa“,  
      „value“: 988.7  
    }  
  ]  
}  
}
```

W&T

With

`http://<ip-address>/rest/json/iostate/sensor/0`

The status of the first sensor can be specifically queried

```
{
  „iostate“: {
    „sensor“: [{
      „name“: „Temperatur“,
      „number“: 0,
      „unit“: „°C“,
      „value“: 23.2
    }]
  }
}
```

10.4 Cloud

The W&T cloud service is a complete solution which not only allows long-term documentation of measurement data in the internal data logger but also makes it possible to save the data in online storage.

Measurement data are passed directly from the measurement point to the cloud, where they are then available online.

A user account is required for the W&T cloud. This can be created on the web pages at:

`http://cloud.wut.de`

10.5 Web-API

Another possible action is to send an HTTP request, as it is used by some devices, e.g. Cameras, to request measured

W&T

values.

Enter the HTTP request as the complete URL with all parameters expected by the device.

E.g.

`http://<IP/Hostname>/single`

10.6 Socket-API

You can retrieve measurement data directly from the device via a socket access.

In the simplest case, send the „GET / Single“ command to the device to return all measured data from the device.

Configure the settings for HTTP and UDP access here.

10.7 RSS

The device provides an RSS feed which can be subscribed to by feed readers. Here you configure the necessary channel settings.

10.8 SNMP/Syslog

Here is where you make the SNMP and syslog basic settings.

The device can be incorporated into your existing automation system via SNMP or syslog.

Retrieve device and sensor data using corresponding OIDs or send messages via SNMP trap or syslog.

An MIB is available for direct downloading at

`http://<ip-address>/mib.zip`

W&T

10.9 FTP

Measurement data can be stored directly on an FTP server for archiving and checking. Here you configure the basic settings for the FTP server.

11 Alarms/Messages

Messages for limit violations are received as soon as they occur via e-mail or SNMP trap. Here you select the desired trigger and configure the desired messaging type. You can configure up to 12 different messages.

Alarms/Messages

Notifications keep you up to date e.g. by e-mail or SNMP trap over limit value overruns/underruns. Select the desired trigger and configure the desired notification type. You can configure up to 12 different messages.

Add		
Alert E-Mail	Trigger	Delete
FTP Report	Trigger	Delete
SNMP Trap	Trigger	Delete

Clicking on the button **Add** a new message. Enter the desired parameters and select the type of messages. After creating the message using the button **Apply**, monitoring of the triggering condition is immediately active.

You can find the created message both in the configuration menu and on the overview page for messages. Here you are also able to test messages by clicking on the button **Trigger**. The configured message is then triggered exactly once.

The button **Delete** deletes the message. This change becomes effective immediately after a security prompt.

To incorporate measurement values into the message texts the following tags are used which are replaced within the text

by the available values.

W&T tag value		Function
comma spelling (##, #)	dot spelling (##. #)	
<T1>	<t1>	<i>Temperature</i> : Displays the current temperature.
<H1>	<h1>	<i>Humidity</i> : Displays the current relative humidity.
<AH>	<ah>	<i>Absolute humidity</i> : Displays the current absolute humidity.
<RC>	<rc>	<i>Rate of change</i> : Displays the rate of change from the last 5 minutes.
<PA>	<pa>	<i>Absolute air pressure</i> : Displays the current absolute air pressure.
<PN>	<pn>	<i>Sea-Level air pressure</i> : Displays the air pressure counted back to Mean Sea Level.
<V>	<v>	<i>VOC</i> : Displays the current air quality value. (#57618)
<O1>	<o1>	<i>Output</i> : Shows the current output state (ON, OFF) (#57616)
<AA>		<i>Alarm active</i> : Shows all alarms (numbers, komma separatet) which are currently active.
<AN>		<i>Alarm sensor number</i> : Shows all sensors (numbers, komma separated) which match with the configured alarm values per alarm.
<AS>		<i>Alarm sensor name</i> : see above, but with sensor names (komma separated)
<DN>		<i>Device Name</i> : Shows the device name.

W&T tag date + time	
<Z>	Displays the actual time and date as a string.
<\$y>	<i>Year (####)</i> : Displays the year.
<\$m>	<i>Month (##)</i> : Displays the month.
<\$d>	<i>Day (##)</i> : Displays the day.
<\$h>	<i>Hour (##)</i> : Displays the hour.
<\$i>	<i>Minute (##)</i> : Displays the minute.
<\$s>	<i>Second (##)</i> : Displays the second.

12 Diagnosis

Here you will find all the runtime errors which the device has generated.

[WEBIO-07255D](#) >> **Diagnosis**

Diagnosis

18.09.2015 10:18:07: DNS: server reply not recognized

Diagnosis Archive

18.09.2015 10:17:46: System: Network malfunction or bad configuration.

18.09.2015 10:17:46: Time Server sychronisation not successful

Clear Report

Errors which have occurred but which are no longer current can be found in the diagnostics archive.

Errors occurring while entering parameters do not appear on this page, but rather are displayed directly on the parameter.

Invalid value
Alert name:

13 Device information

Here you find descriptive information about your device and manufacturer's descriptions. The contents of this information can be changed in the basic settings under Language/Infos.

[WEBIO-07255D](#) >> **Device information**

Device information

Manufacturer and hardware information

Web-Thermo-Hygrobarometer 	
Hersteller:	Wiesemann & Theis GmbH
Address:	Porschestra. 12 42279 Wuppertal Germany
Support Hotline:	+49-(0)202-2680-0
Internet:	http://www.wut.de
Type:	Web-Thermo-Hygrobarometer
Article Number:	#57713
System Name:	WEBIO-07255D
Description:	
IP-address:	10.40.23.27
Datasheet:	http://www.wut.de/57713
Software revision:	1.0
Sensor type temperature:	W&T Temp
Sensor type humidity:	W&T rH
Sensor type air pressure:	W&T hPa
MAC address:	00:C0:3D:07:25:5D
DHCP: DNS Server:	0.0.0.0
DHCP: Lease Time:	00:00:00

14 Maintenance

WEBIO-078349 >> Maintenance

Maintenance

Device reboot, reset, backup and restore.

Maintenance		▲
Reboot device:	<input type="button" value="Reboot"/>	<input type="button" value="i"/>
Restore device:	<input type="button" value="Factory defaults"/>	<input type="button" value="i"/>

Config		▲
Save configuration:	<input type="button" value="Download"/>	<input type="button" value="i"/>
Restore configuration:	<input type="button" value="Datei auswählen"/> <input type="button" value="Keine ausgewählt"/>	<input type="button" value="i"/>

14.1 Reboot

Restarts the device and resets all network connections.

14.2 Factory defaults

The device is reset to the factory default settings. All configuration parameters and passwords are cleared. After a reset you must start over with IP address assignment.

14.3 Save configuration

Clicking on the Download button downloads a file containing the entire device configuration. This can be edited in a text editor.

14.4 Restore configuration

Select a configuration file and upload it to the device. After a restart all the configuration parameters are applied by the device

15 Individual request of measurement values

15.1 Request via TCP/IP Socket API

It is possible to manually request the current measurement values in CSV format (comma-separated data) through a socket connection. This function is used for requesting individual data without using the web interface.

To do this, activate the TCP ASCII Sockets function under *Communication paths >> Socket API* and enter the desired server port (default: 42280).

```
GET /Thermo.csv
```

This expression can also include additional parameters which determine the contents:

```
start=ttmmjjjjThhmss
```

Start-date and -time for the measurement data to be loaded

```
end=ttmmjjjjThhmss
```

End-date and -time for the measurement data to be loaded

```
DTb=x&
```

Output interval, where x =

- 1 -> 15 Sek.
- 2 -> 30 Sek.
- 3 -> 1 Min.
- 4 -> 5 Min.
- 5 -> 15 Min.
- 6 -> 60 Min.

The expression must begin with “?” after the file name, where the individual variables are separated by a “&”.

Example:

```
http://<ip-adresse>/thermo.csv?start=01012010T123000&end=30032010T200000&DTb=3&
```

The above expression generates a CSV file which contains the measurement data from 01.01.2010, 12:30 p.m. until 03.30.2010, 8:00 p.m. in 1 minute intervals.

To request the individual current measurement value, send:

```
GET /Single1  
for the 1st measuring channel
```

```
GET /Single2  
for the 2nd measuring channel, etc.
```

To receive an output for all measuring channels, send:

```
GET /Single  
without Index.
```

15.2 Requesting via UDP Socket API

To do this, activate the UDP Sockets function under *Communication paths >> Socket API* and enter the desired server port (default: 42279).

Open a UDP connection to the IP address of the device, or to the Net ID as broadcast and this port.

Then send the device one of the GET / single expressions given above and the device returns the measured values on the port you are using.



When using multiple devices it may make sense to also have the name and IP address of the device included with broadcast messages. To do this, select "Prepend IP address and system name" under "Communication paths >> Socket access".

15.3 Requesting via SNMP

The sensors can be queried directly using SNMP instructions.

The paths of the different model variations are:

#57713 Web-Thermo-Hygrobarometer:

1.3.6.1.4.1.5040.1.2.**37**....

#57714 Web-Thermometer NTC:

1.3.6.1.4.1.5040.1.2.**38**....

#57715 Web-Thermometer Pt100/Pt1000:

1.3.6.1.4.1.5040.1.2.**39**....

#57716 Web-Thermometer Relay:

1.3.6.1.4.1.5040.1.2.**40**....

#57718 Web-Thermometer Air Quality:

1.3.6.1.4.1.5040.1.2.**41**....

#57720 Web-Thermo-Hygrometer

1.3.6.1.4.1.5040.1.2.**42**....

#57708 Web-Thermometer 2x

1.3.6.1.4.1.5040.1.2.**43**....

#57708 Web-Thermometer 8x

1.3.6.1.4.1.5040.1.2.**44**....

Access the sensors through the following path:

<IP-Adresse> 1.3.6.1.4.1.5040.1.2.X.1.3.1.1.1 = First channel with a decimal point with comma separation

<IP-Adresse> 1.3.6.1.4.1.5040.1.2.X.1.4.1.1.1 = First channel as three place integer value, without comma separation

<IP-Adresse> 1.3.6.1.4.1.5040.1.2.X.1.8.1.1.1 = First channel with one decimal place with decimal point separation

The last index describes the channel number you are querying.



For querying indicate the configured SNMP read or read/write community.

An MIB for incorporating into management applications is available for downloading on the datasheet page of the device on the W&T homepage <http://www.wut.de> or in the device itself at <http://<ip-address>/mib.zip>.

If you wish to change device settings via SNMP (IP address, subnet mask, etc.) you must first start a session on the device using your SNMP manager.

Entering the administrator password in the variable

```
wtWebGraphThermoBaroSessCntrlPassword
```

opens a session. By reading the variable

```
wtWebGraphThermoBaroSessCntrlConfigMode
```

you can check whether the session was successfully opened.

1 = Session opened, device is in configuration mode.

0 = Opening of the session failed. Check whether an

W&T

incorrect password was entered.

After successfully opening the session, you can make any desired configuration changes using the variables defined in the private MIB.

After configuration is finished, close the session by writing the variables

```
wtWebGraphThermoBaroSessCntrlLogout
```

```
wtWebGraphThermoBaroSessCntrlLogout =
```

- 1 All changes are saved
- 2 Quit without saving

If while a session is open no SNMP communication takes place for a period of 5 minutes, the device itself will close the session and all changes are discarded.



Opening an SNMP session has priority over an HTTP login. This means: A user with operator or administrator rights loses his browser access as soon as an SNMP session is opened.

The description of the individual SNMP variables, OIDs etc. can be found in the private MIB.

16 Firmware Update

The operating software for the Web-Thermometer is being continuously improved. The following section describes the procedure for uploading new firmware.

- Where is the latest firmware available?
- Firmware update under Windows

16.1 Where is the latest firmware available?

The most current firmware including the available update tools and a revision list are published on our website at the following address: <http://www.wut.de>

Please first write down the 5-digit model number located on the Web-Thermometer before downloading. From the homepage you can then reach the product overview sorted by article numbers, which takes you directly to the datasheet for the device. Here you follow the link to the current version of the firmware.

16.2 Firmware update over the network under Windows

Prerequisite is a PC running Windows XP/Vista/7/8/8.1/10 with a network connection and activated TCP/IP stack. The update process requires two files which are as noted above are available for downloading on the homepage at <http://www.wut.de>:

- The executable WuTility tool for sending the firmware to the

Web-Thermometer

- The file with the new firmware for sending to the device.

No special preparation of the Web-Thermometer is necessary for the firmware update.

The WuTility tool used for the update detects all WuT devices located in your network and is for the most part self-explanatory. If any questions arise, please use the associated documentation or go to online help.



Do not intentionally interrupt the update process by disconnecting power or pressing the Reset button if one is present. The Web-Thermometer will be inoperable after an incomplete update

Never mix files with different version numbers in file names. This will cause the device to become inoperable.

The Web-Thermometer automatically detects when the transfer of the new operating software is complete and then performs an automatic reset.

17 Hardware-Reset to factory defaults

A reset of the device to its factory defaults can be done via hardware. For this purpose the device has a jumper on the board. For normal operation this jumper must be out. To set the factory defaults, proceed as follows:

- Power off the device and open the enclosure
- Close the jumper and reconnect the supply voltage. An internal self-test will be performed during which messages will be issued on serial port. The *Fail* messages in the lines *Port A:* and *TP Test:* can be ignored.
- The self-test will be finished in approx. 20s, at which point the factory defaults are active.
- Turn off the device, open the jumper and close up the housing again.



Resetting the non-volatile memory results in a loss of all the settings which are different from the factory defaults, including the IP address, passwords and all measured values.

Modell #57708, ab 2018

The Web-Thermometer 8x no longer has a jumper in the 2018 model. For emergency access, the reset button is used, which is now recessed in the device. You can recognize the new model by this recessed button. The procedure described above still applies to the predecessor model.

Delete password

Use a pointed object on the web thermometer to press the reset button recessed in the front of the housing. Press and hold the reset button until the status and error LEDs on the lower board start flashing slowly. Release the reset button.

By entering the IP address of the web thermometer as URL in

the browser, you will be taken to an emergency access website where you can reset your passwords.

Reset to factory settings

Use a pointed object on the web thermometer to press the reset button recessed in the front of the housing. Press and hold the reset button until all status LEDs start flashing slowly and quickly after a while. Release the reset button.

The configuration of the Web-IO now corresponds to the delivery status.

18 Technical data

18.1 Technical data for the articles 57714 and 57715

Prod. No.	57714, 57715
Network:	10/100BaseT autosensing
Supply voltage:	Power-over-Ethernet or 12-48V DC (+/-10%) or 18Veff-30Veff AC (+/-10%) via screw terminal
Measuring unit (57714)	
Sensor:	NTC 10k
Measuring range:	-45°C...75°C
Resolution:	1/10°C
Measuring error:	±0,3°C, ±5,1%
Storage frequency:	15, 30 sec, 1, 5, 15, 60 min
Memory depth (4MB):	min. 16 weeks, max. 20 years
Deviation of the internal clock:	max. 1 min. / Month
Measuring unit (57715)	
Sensor:	Pt100, Pt1000 connection, 2-, 3- or 4-conductor
Measuring range:	W&T sensor: -50°C...180°C PT100/PT1000 measuring input: -200°C...650°C
Resolution:	1/10°C
Measuring error:	±0,3°C, ±0,2%
Storage frequency:	15, 30 sec, 1, 5, 15, 60 min
Memory depth (4MB):	min. 16 weeks, max. 20 years
Deviation of the internal clock:	max. 1 min. / Month
Power supply	
Current consumption:	typ. 62mA @24VDC, 80mA @20VAC, max. 70mA @24VDC, 40mA @48VDC PoE Class 1 (0,44 - 3,84W)
Emergency access:	serial port RS232, 9600 baud, 8 data bits, 1 stopbit, no parity
Housing:	Compact plastic housing, 105 x 75 x 22mm (lxwxh)
Weight:	approx. 200g
Ambient storage temperature:	-40...+70°C
Ambient operating temperature:	non-row mounting: 0 .. +60°C row mounting: 0 ..+50°C

18.2 Technical data for the articles 57713 and 57720

Prod. No.	57713, 57720
Thermo-Hygro Probe:	I2C connection
Air pressure probe:	SPI connection (57713 only)
Network:	10/100BaseT autosensing
Supply voltage:	Power-over-Ethernet or 12-48V DC (+/-10%) or 18Veff-30Veff AC (+/-10%) via screw terminal
Measuring unit	
Measuring range:	-40°C...85°C, 0..100% rF, 10-1100 hPa (57713 only)
Resolution:	1/10 °C, 1/10% rF, 0.1 hPa
Measuring error:	Temperature: typ. @ 25°C ±0.3°C max. @ -40..85°C ±1.5°C Relative humidity: typ. @ -20..60°C (normal range) ±1.8%rH (10-90%rH) max. @ -20..60°C (normal range) ±4%rH (0-100%rH) temporary @ -40..85°C (max range) +3%rH after 60h Operation outside normal range Long-term stability typ. <0.5%rH / year Atmospheric pressure (57713 only): typ. @ 25°C ±0.8hPa (750..1100hPa) max. @ 25°C ±2.5hPa (750..1100hPa) max. @ -40..85°C: ±3.5hPa (300..1100hPa) Long-term stability: typ. -1 hPa / year
Storage frequency:	15, 30 sec, 1, 5, 15, 60 min
Memory depth (4MB):	min. 7 weeks, max. 20 years (57713) min. 12 weeks, max. 20 years (57720)
Deviation of the internal clock:	max. 1 min. / Month
Power supply	
Current consumption:	typ. 62mA @24VDC, 80mA @20VAC, max. 70mA @24VDC, 40mA @48VDC PoE Class 1 (0,44 - 3,84W)
Emergency access:	serial port RS232, 9600 baud, 8 data bits, 1 stopbit, no parity
Housing:	Compact plastic housing, 105 x 75 x 22mm (lxwxh)
Weight:	approx. 200g
Ambient storage temperature:	-40..+70°C
Ambient operating temperature:	non-row mounting: 0 .. +60°C row mounting: 0 ..+50°C

18.3 Technical data for the article 57716

Prod. No.	57716
Thermo-Probe:	Pt100/Pt1000-Connection via screw terminal
Network:	10/100BaseT autosensing
Supply voltage:	Power-over-Ethernet or 12-48V DC (+/-10%) or 18Veff-30Veff AC (+/-10%) via screw terminal
Measuring unit	
Sensor:	Pt100/Pt1000-Connection, 2-,3- or 4-wire
Measuring range:	W&T Sensor: -50°C...180°C PT100/PT1000-Input: -200°C...650°C
Resolution:	1/10°C
Measuring error:	
Measuring unit:	±0,3°C, ±0,2%
PT100/1000 Sensor Class A:	±0,15°C, ±0,2%
Storage frequency:	15, 30 sek, 1, 5, 15, 60 min
Memory depth (4MB):	min. 16 weeks, max. 20 years
Deviation of the internal clock:	max. 1 min. / month
Semiconductor-Relay-Output	
Digital output:	1 potential-free semiconductor-relay
max. switching current:	typ. 300mA AC/DC (peak 500mA)
max. switching voltage:	39V AC/DV
max. power consumption:	11,7W AC/DC
Power supply	
Current consumption:	typ. 62mA @24VDC, 80mA @20VAC, max. 70mA @24VDC, 40mA @48VDC PoE Class 1 (0,44 - 3,84W)
Housing:	Plastic compact housing, 105x75x22mm
Weight:	approx. 200g
Ambient storage temperature:	-40..+70°C
Ambient operating temperature:	non-row mounting: 0 .. +60°C row mounting: 0.. +50°C

18.4 Technical data for the article 57718

Prod. No.	57718
Thermo-Hygro Probe:	I2C connection
VOC probe:	I2C connection
Network:	10/100BaseT autosensing
Supply voltage:	Power-over-Ethernet or 12-48V DC (+/-10%) or 18Veff-30Veff AC (+/-10%) via screw terminal
Measuring unit	
Measuring range:	0°C...50°C, 5..95% rF, 450-2000ppm VOC/CO2 Equivalent
Resolution:	1/10 °C, 1/10% rH
VOC sensor, detected substances:	Alcohols Aldehydes aliphatic hydrocarbons Amines Aromatic hydrocarbons CO, CH4, LPG Ketones Organic acids
Measuring error:	Temperature: typ. @ 25°C ±0.3°C max. @ 0..50°C ±1.2°C
	Relative humidity: typ. @ 25°C ±3%rH max. @ 0..50°C ±7%rH (0-100%rH) Long-term stability typ. <0.5%rH / year
Storage frequency:	15, 30 sek, 1, 5, 15, 60 min
Memory depth (4MB):	min. 7 weeks, max. 20 years
Deviation of the internal clock:	max. 1 min. / month
Power supply	
Current consumption:	typ. 62mA @24VDC, 80mA @20VAC, max. 70mA @24VDC, 40mA @48VDC PoE Class 1 (0,44 - 3,84W)
Housing:	Plastic compact housing, 105x75x22mm
Weight:	approx. 200g
Ambient storage temperature:	-25+50°C
Ambient operating temperature:	non-row mounting: 0 .. +60°C row mounting: 0 ..+50°C

18.5 Technical data for the article 57707

Prod. No.	57707
Network:	10/100BaseT autosensing
Supply voltage:	Power-over-Ethernet (PoE) or DC 12V .. 48V (+/-10%) via screw terminal
Measuring unit	
Sensor:	2x Pt100, Pt1000 connection, 2-, 3- or 4-conductor via 8-pin terminal block Conductor cross-section 0.2-1.3mm ² Stripped length 6-8mm
Measuring range:	W&T sensor: -50°C...180°C PT100/PT1000 measuring input: -200°C...650°C
Resolution:	1/10°C
Measuring error:	±0,3°C, ±0,2%
Storage frequency:	15, 30 sec, 1, 5, 15, 60 min
Memory depth (4MB):	min. 4 weeks, max. 20 years
Deviation of the internal clock:	max. 1 min. / Month
Power supply	
Current consumption:	PoE Class 1 (0.44 - 3.84W) typ. 70mA @ 24V DC with external supply
Housing:	Plastic compact housing for top-hat rail mount 105x22x75mm (LxWxH)
Weight:	approx. 200g
Ambient storage temperature:	-40..+70°C
Ambient operating temperature:	non-row mounting: 0 .. +60°C row mounting: 0 ..+50°C

18.6 Technical data for the article 57708

Prod. No.	57708
Network:	10/100BaseT autosensing
Supply voltage:	Power-over-Ethernet or 12-48V DC (+/-10%) or 18Veff-30Veff AC (+/-10%) via screw terminal
Measuring unit	
Sensor:	8x Pt100, Pt1000 connection, 2-, 3- or 4-conductor
Measuring range:	W&T sensor: -50°C...180°C PT100/PT1000 measuring input: -200°C...650°C
Resolution:	1/10°C
Measuring error:	±0,3°C, ±0,2%
Storage frequency:	15, 30 sec, 1, 5, 15, 60 min
Memory depth (4MB):	min. 4 weeks, max. 20 years
Deviation of the internal clock:	max. 1 min. / Month
Power supply	
Current consumption:	typ. 65mA @24VDC, 140mA @18VAC, max. 80mA @24VDC, 45mA @48VDC PoE Class 1 (0,44 - 3,84W)
Emergency access:	serial port RS232, 9600 baud, 8 data bits, 1 stopbit, no parity
Housing:	Compact plastic housing, 106,8x87,8x62,6mm (lxxh)
Weight:	approx. 200g
Ambient storage temperature:	-40..+70°C
Ambient operating temperature:	non-row mounting: 0 .. +60°C row mounting: 0 ..+50°C

19 Disposal

This device contains a non-rechargeable lithium button battery type BR (lithium carbon monofluoride) for retaining the time even when the device is turned off. This battery must be disposed of after its useful life has expired. Take it to an official collection site for recycling.

First disconnect all cables from the device and open the device.

The button battery is located on the circuit board. Remove it from its holder and take it to a recycler.