

W&T

www.WuT.de

Manual

Installation, Startup and Application

Industry Interface Converters

valid for:

#64201: Interface 20mA <> RS422/RS485

#66201: RS422/RS485 Isolator

#66203: RS422/RS485 Isolator OVP

#80201: RS232 Line Driver Set

#84201: Interface RS232 <> 20mA

#86201: Interface RS232 <> RS422/RS485

#86203: Interface RS232 <> RS422/RS485 OVP

#88205: RS232 Isolator

Release 01/2019

© 01/2019 by Wiesemann & Theis GmbH

Subject to errors and changes:

Since we can make mistakes, none of our statements should be used without checking. Please let us know of any mistakes or misunderstandings you are aware of, so that we can recognize and eliminate them quickly.

Perform work on and with W&T products only as described here and only if you have read and understood the manual fully. Unauthorized use can result in hazards. We are not liable for the consequences of unauthorized use. When in doubt, check with us or consult your dealer!

Wiesemann & Theis offers with their Industry Interfaces a complete family of interface converters suitable for top hat rail mounting and powered by the 24V supply commonly used in industrial environments.

Trouble-free, noise-immune operation of the associated components is ensured by integrated galvanic isolation between the two interfaces used as well as between the power supply and the interfaces.

This interface family is described on the following pages along with the corresponding technical data and including connection examples.

For up-to-date information on new developments, see our Internet site at <http://www.wut.de> or check the e-mail short notices at the W&T Interface Club, which you can also subscribe to from the W&T Homepage.

Index

Legal Notices5
Safety Instructions7
General Characteristics11
RS232 <> 20mA Converter, Model 8420113
RS232 <> RS422/RS485 Converter, Model 8620117
RS232 <> RS422/RS485 Converter OVP, Model 8620317
20mA <> RS422/RS485 Converter, Model 6420123
RS232 Isolator, Model 8820529
RS422/RS485 Isolator, Model 6620133
RS422/RS485 Isolator OVP, Model 6620333
RS232 Line Driver Set, Model 8020141

Legal Notices**Warning note concept**

This manual contains notes which must be observed for your personal safety and to prevent equipment damage. The notes are called out with a warning triangle. Depending on the hazard level the warning notes are represented in decreasing order of hazard as follows:

 DANGER

Indicates a hazard which will result in death or serious injury if no appropriate safety measures are taken.

 WARNING

Indicates a hazard which can result in death or serious injury if no appropriate safety measures are taken.

 CAUTION

Indicates a hazard which can result in slight injury if no appropriate safety measures are taken.

 NOTE

Indicates a hazard which can result in equipment damage if no appropriate safety measures are taken.

When multiple hazard levels are present the warning note for the highest level is used. If the warning triangle for personal injury is used, then a warning for equipment damage may also be added in the same warning note.

Qualified personnel

The product described in this manual may be installed and placed in operation only by personnel who are qualified for the respective task.

In addition the documentation for the respective task must be followed, especially the safety and warning notes included in it.

Qualified personnel have received training and experience which enable them to recognize risks associated with handling the described products and to avoid possible hazards.

Disposal

Electronic devices may not be disposed of with household waste, but rather be brought to a proper electronics waste disposal facility.

A complete Declaration of Conformity for the described devices can be found on the respective datasheet pages on the W&T Homepage at <http://www.wut.de>.

Safety Instructions

General precautions

CAUTION

This manual is intended for the installer of the described devices and must be read and understood before beginning any work.

The interface converters are to be installed and placed in service only by an electrical specialist.

Intended use

CAUTION

The intended use of the interface converters is the use in accordance with the information provided in the manual.

The devices may be operated only using the maximum permitted connection values according to the technical data. Any other use or modification is considered to be improper.

Installation** CAUTION**

Before beginning any work on the device the power must be completely disconnected by suitable means. Ensure that it can't be reconnected inadvertently!

Please do not install the interface converters in places with high moisture or near water.

Please do not install the devices in places with high ambient temperature or near heat sources. Please refer to the specification of the maximum ambient temperature.

The ventilation holes must be kept free from any obstructions. Also a 10-15 cm clearance must be kept when the adjacent device is a heat source.

Make sure that no loose wires extend into the housing of the power supplies through the ventilation holes.

Make sure that all strands of each stranded wire enter the power terminal connection and the screw terminals are securely fixed to prevent poor contact.

Electrical Safety

DANGER

Both ports of all W&T Interface Converters are isolated from each other and from the power supply with a dielectric strength of 1000 volts DC.

This allow the interface converters to suppress compensation currents which can flow as a result of potential differences between the connected devices when directly copper connections are used. Such currents can cause interference with data transmission or even destroy the interfaces.

The galvanic isolation of the interface converters described in this manual are designed for protecting the serial ports and for ensuring noise-free data transmission in noisy environments. Use of the devices to protect persons against contact with hazardous voltages is not permitted. For safety-critical galvanic isolation, please contact us.

Make sure that there is enough space between the cables leading to the serial ports of the interface converters to avoid any potential flashovers between the cables.

With a maximum permissible supply voltage of 24V AC or DC (SELV), the described devices do not fall under the Low-Voltage Directive. The power supply must in any case ensure reliable isolation of the low-voltage side from the mains in accordance with EN60950-1.

In addition, the power supply must have an LPS feature.

Protection of operating personnel and the equipment is only assured if the device is used according to its intended purpose. Any other use than described in the manuals may compromise the safety and function of the interface converters and the connected systems.

If a fault is unable to be eliminated, the device must be taken out of service and protected against accidental startup.

Responsibility for adhering to the local prevailing safety regulations lies with the operator.

EMC** NOTE**

All W&T interface converters meet the limits for noise immunity in industrial environments as well as emissions in commercial and residential areas, so that use of these converters is not subject to any EMC based restrictions.

To ensure compliance with the EMC standards, shielded signal cables must be used.

In EMC respects the interface converters are considered independent units, but the final equipment still need to re-confirm that the whole system complies with the EMC directives.

General Characteristics

Housing and setting the DIL switches

All W&T Industry Interfaces are integrated into a plastic housing for mounting on DIN rails.

Some Interface models have DIL switches inside the housing. To set these switches, you must open up the housing. We recommend screwing a SUB-D plug with body onto the Interface and using the plug to help pull the housing cover out of the housing body.

Display elements

The interface converters feature two LED's, with the *Power* LED indicating correct supply voltage and the *Data* LED data communication in both directions.

Power Supply

The W&T Industry Interfaces in DIN rail housing have a broad-range supply voltage input and can be powered either by a suitable W&T power supply or with an external voltage of between 12V and 24 V AC or DC.

The power supply must in any case ensure reliable isolation of the low-voltage side from the mains in accordance with EN60950-1.

In addition, the power supply must have an LPS feature.

The supply voltage feed is reverse polarity protected and is accomplished using the included plug-in screw terminal.

Galvanic isolation and ESD protection

Both ports of all W&T Interface Converters are isolated from each other and from the power supply with a dielectric strength of 1000 volts DC.

The signals are isolated by means of high-speed optocouplers; energy is supplied to the driver and receiver elements by means of an isolated DC/DC converter.

All signal lines of the interface converters are protected against electrostatic discharge of up to 15kV according to IEC 801-2, level 4.

RS232 <> 20mA Converter, model 84201

The W&T Interface Converter Model 84201 permits bi-directional connection of RS232 devices with components, which are equipped with an 20mA port.

Function

The interface converts one data line in each direction and provides electrical isolation between the RS232 side and the 20mA side.

Connectors

The two ports of the interface use DB9 male connectors. The connector pin assignments are shown in the table below:

Pin#	RS232 signal
2	data in
3	data out
4	active level
5	signal GND
7	active level

Pin#	20mA signal
1	data out 20mA
2	data out +
3	data out -
4	data out GND
5	halfduplex control
6	data in 20mA
7	data in +
8	data in -
9	data in GND

Applications

A GND level signal on Pin 5 of the TTY connector will place the 20mA interface of the convertor in half-duplex mode whereby an echo of the sent signals is suppressed. The convertor can be used as an active or passive 20mA component. In the active mode the interface supplies the current required by the respective 20mA loop, while in the passive mode the loop current must be supplied by the connected device. The operating mode can be selected for both loops separately. Examples of interface switching into active/ passive mode are shown on the following drawings:

Tx and Rx loop active

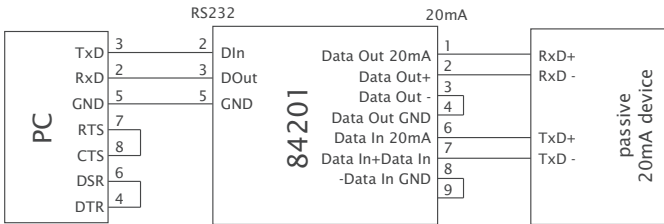

Tx and Rx loop passive

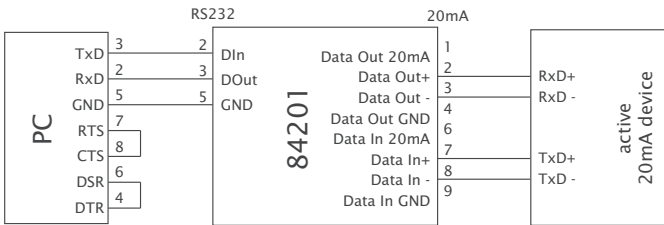

Tx loop active, Rx loop passive

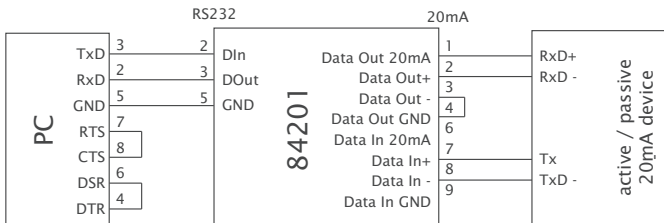

Technical Data

Operating modes:	active or passive mode
Baud rate:	0..19,200 baud
Data format:	any format
Supported signals:	RxD, TxD
RS232 adapter:	9-pin male SUB-D adapter
20mA adapter:	9-pin male SUB-D adapter
Electrical isolation:	both ports from each other and from power supply with a dielectric strength of 1000 volts DC
Power supply:	12..24V DC/AC
Current consumption:	typ. 120mA @12V, 60mA @ 24V DC
Power connection:	Plug-in screw terminal, 5.08mm spacing, labeled „L+“ and „M“
Ambient temperature:	storage: -40..+70°C Operating in non-rowed installation: 0..+60°C Operating in rowed installation: 0..+50°C
Relative humidity:	5..95% rH (non-condensing)
Housing:	small plastic housing for top hat rail mounting
Dimensions:	105x75x22mm
Device weight:	approx. 100g
Delivery:	RS232 <> 20mA Converter

RS232 <> RS422/485 converter, Model 86201 & 86203

The W&T Interface Converters Model 86201 and Model 86203 permit bi-directional connection of RS232 devices with components, which are equipped with an RS422 or RS485 port.

Function

The interfaces convert one data line and one handshaking line in each direction and provide electrical isolation between the RS232 side and the RS422/RS485 side.

Connectors

The two ports of the interfaces use DB9 male connectors. The connector pin assignments are shown in the table below:

Pin#	RS232 signal
2	data in
3	data out
4	handshake out
5	signal GND
8	handshake in

Pin#	RS422/485 signal
1	data out A (-)
2	data in A (-)
3	handshake out A (-)
4	handshake in A (-)
5	signal GND
6	data out B (+)
7	data in B (+)
8	handshake out B (+)
9	handshake in B (+)

Overvoltage protection (Model 86203 only)

The maximum differential voltage allowed to reach the RS485 transceiver chip of the interfaces from the outside is around $\pm 12...14V$ according to the data sheets. Voltage exceeding this amount will inevitably result in destruction of the line drivers.

Interface model 86203 has integrated overvoltage protection which uses suppressor diodes to limit the maximum voltage to approx. $\pm 9V$.

This overvoltage protection is limited of course by the capacity of the protection diodes used, which can let through a current of 20A for a short time. This means it may not be a substitute for a lightning surge arrestor for long cables in exposed locations (e.g. in the mountains).

Operating mode

The interfaces can be set for five operating modes by DIP switch setting on the RS422/RS485 interface module. The selectable operating modes are briefly described here:

RS422, RS485 4-wire bus master application

One data channel and one handshake channel in each direction are available. The RS422/RS485 receivers and transmitters are always active in this operating mode.

RS485 4-/2-wire application with echo, handshake control

One data channel in each direction is available. The RS485 output driver is activated with a positive RS232 handshake in signal, while a negative signal forces the driver to high impedance state. The RS485 receiving channel is always active in this operating mode.

RS485, 2-wire application w/o echo, handshake control

One data channel in each direction is available. The RS485 output driver is activated with a positive RS232 handshake in signal, while a negative signal forces the driver to high impedance state. The RS485 receiving channel is deactivated when the driver is on, but is switched on when the driver is in the high impedance state.

RS485, 4-/2-wire application with echo, automatic control

One data channel in each direction is available. The RS485 output driver is activated automatically with each transmission of data, and goes to the high impedance state again after the end of transmission. The RS485 receiving channel is always active in this operating mode.

RS485, 2 wire application w/o echo, automatic control

One data channel in each direction is available. The RS485 output driver is activated automatically with each transmission of data, and goes to the high impedance state again after the end of transmission. The RS485 receiving channel is deactivated when the driver is on, but is switched on when the driver is in the high impedance state

Setting the operating modes

Please see the following table for an explanation of the operating mode DIP switch:

Operating mode	SW1	SW2	SW3	SW4	SW5	SW8
RS422, RS485, 4-wire bus master application	OFF	OFF	OFF	ON	OFF	OFF
RS485, 4-/2-wire application with echo, handshake control	OFF	OFF	ON	ON	OFF	OFF
RS485, 2-wire application without echo, handshake control	ON	OFF	ON	ON	OFF	OFF
RS485, 4-/2-wire application with echo, automatic control	OFF	ON	OFF	ON	OFF	OFF
RS485, 2-wire application without echo, automatic control	ON	ON	OFF	ON	OFF	OFF

Termination

For all RS485 operating modes it is essential that the bus system be terminated with a termination network which assures a defined rest state in the high-impedance phases of bus operation. The bus system can be connected to a termination network by closing switches #6 and #7 on the interface module.

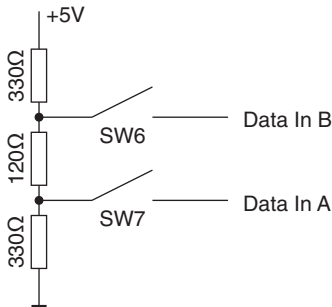

Applications

RS422 application with hardware handshake

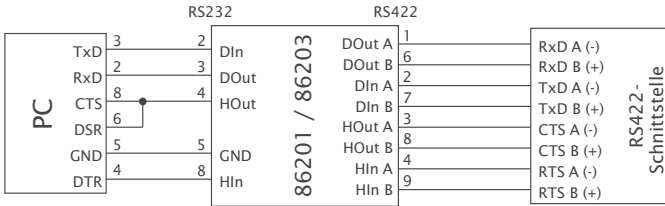

RS485 4-wire bus master application

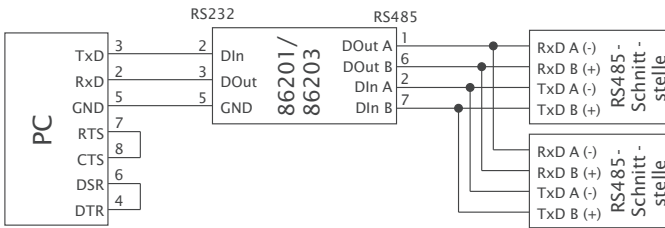

RS485 2-wire application with handshake control

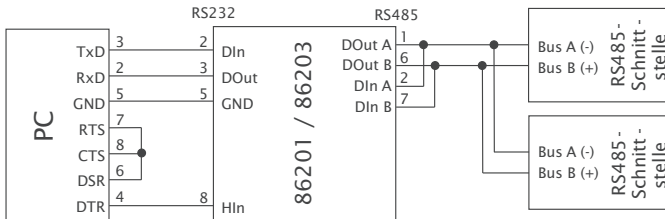

RS485 2-wire application with automatic control

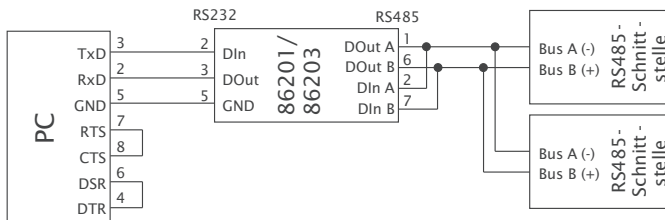

Technical Data

Operating modes:	RS422 RS485 2/4 wire mode withhandshake control RS485 2/4 wire mode with automatic control
Switchover delay:	approx. 10 μ s from transmit to receive for RS485 automatic control (can be factory changed on request)
Baud rate:	0..115,200 baud
Data format:	any format
Supported signals:	RxD, TxD, CTS, DTR
RS232 adapter:	9-pin male SUB-D adapter
RS422/RS485 adapter:	9-pin male SUB-D adapter
Termination:	Switchable termination network for RS485 operation
Electrical isolation:	both ports from each other and from power supply with a dielectric strength of 1000 volts DC
Overvoltage protection:	Model 86203 only: limiting of differential voltage by suppressor diodes to $V_{max} = 9,2V$ ($I_{max} = 20A$, $t = 10/1000\mu s$)
Power supply:	12..24V DC/AC
Current consumption:	typ. 80mA @12V, 40mA @24V DC
Power connection:	Plug-in screw terminal, 5.08mm spacing, labeled „L+“ and „M“
Ambient temperature:	storage: -40..+70°C operation: 0..+60°C
Relative humidity:	5..95% rH (non-condensing)
Housing:	small plastic housing for top hat rail mounting
Dimensions:	105x75x22mm
Device weight:	approx. 100g
Delivery:	RS232 <> RS422/RS485 Converter

20mA <> RS422/RS485 Converter, Model 64201

The W&T Interface Converter Model 64201 permits bi-directional connection of 20mA devices with components, which are equipped with an RS422 or RS485 port.

Function

The interface converts one data line in each direction and provides electrical isolation between the 20mA side and the RS422/RS485 side.

Connectors

The two ports of the interface use DB9 male connectors. The connector pin assignments are shown in the table below:

Pin#	RS422/485 signal
1	data out A (-)
2	data in A (-)
5	signal GND
6	data out B (+)
7	data in B (+)

Pin#	20mA signal
1	data out 20mA
2	data out +
3	data out -
4	data out GND
5	halfduplex control
6	data in 20mA
7	data in +
8	data in -
9	data in GND

Operating modes of the 20mA interface

A GND level signal on Pin 5 of the TTY connector will place the 20mA interface of the convertor in half-duplex mode whereby an echo of the sent signals is suppressed.

The convertor can be used as an active or passive 20mA component. In the active mode the interface supplies the current required by the respective 20mA loop, while in the passive mode the loop current must be supplied by the connected device. The operating mode can be selected for both loops separately. Examples of interface switching into active/passive mode are shown on the applications page.

Operating modes of the RS422/RS485 interface

The interface can be set for three operating modes by DIP switch setting on the RS422/RS485 interface module. The selectable operating modes are briefly described here:

RS422, RS485 4-wire bus master application

One data channel and one handshake channel in each direction are available. The RS422/RS485 receivers and transmitters are always active in this operating mode.

RS485 4-wire bus systems

One data channel in each direction is available. The RS485 output driver is activated automatically with each transmission of data, and goes to the high impedance state again after the end of transmission. The RS485 receiving channel is always active in this operating mode.

RS485 2-wire bus systems

One data channel in each direction is available. The RS485 output driver is activated automatically with each transmission of data, and goes to the high impedance state again after the end of transmission. The RS485 receiving channel is deactivated when the driver is on, but is switched on when the driver is in the high impedance state.

Setting the operating modes

Please see the following table for an explanation of the operating mode DIP switch:

Operating mode	SW1	SW2	SW3	SW4	SW5	SW8
RS422, RS485, 4-wire bus master	OFF	OFF	OFF	ON	OFF	OFF
RS485, 4-wire bus system	OFF	ON	OFF	ON	OFF	OFF
RS485, 2-wire bus system	ON	ON	OFF	ON	OFF	OFF

Termination

For all RS485 operating modes it is essential that the bus system be terminated with a termination network which assures a defined rest state in the high-impedance phases of bus operation.

The bus system can be connected to a termination network by closing switches #6 and #7 on the interface module:

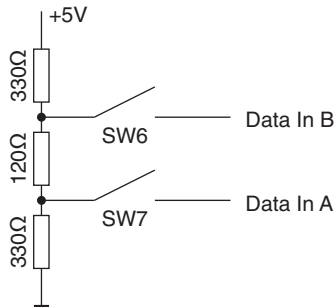

Applications

RS422 <> 20mA, Tx and Rx loop active

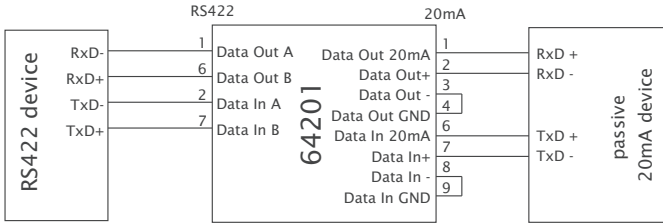

RS422 <> 20mA, Tx and Rx loop passive

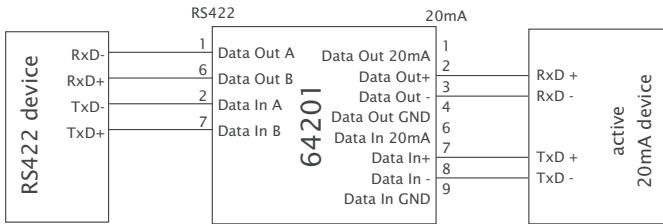

RS422 <> 20mA, Tx loop active, Rx loop passive

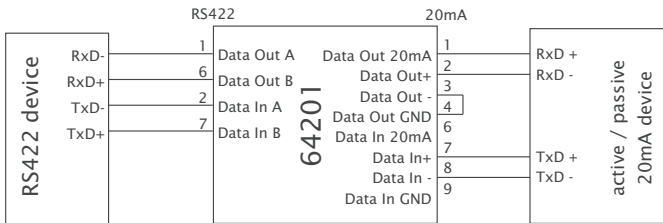

RS485 <> 20mA, Tx loop active, Rx loop passive

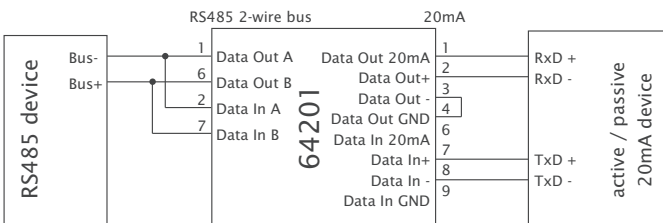

Technical Data

Operating modes:	RS422 RS485 2/4 wire mode with automatic control 20mA: active or passive mode
Switchover delay:	approx. 10 μ s from transmit to receive for RS485 automatic control (can be factory changed on request)
Baud rate:	0..19,200 baud
Data format:	any format
Supported signals:	RxD, TxD
20mA adapter:	9-pin male SUB-D adapter
RS422/RS485 adapter:	9-pin male SUB-D adapter
Termination:	Switchable termination network for RS485 operation
Electrical isolation:	both ports from each other and from power supply with a dielectric strength of 1000 volts DC
Power supply:	12..24V DC/AC
Current consumption:	typ. 130mA @12V, 65mA @24V DC
Power connection:	Plug-in screw terminal, 5.08mm spacing, labeled „L+“ and „M“
Ambient temperature:	storage: -40..+70°C operation: 0..+60°C
Relative humidity:	5..95% rH (non-condensing)
Housing:	small plastic housing for top hat rail mounting
Dimensions:	105x75x22mm
Device weight:	approx. 100g
Delivery:	20mA <> RS422/RS485 Converter

RS232 Isolator, Model 88205

The W&T RS232 Isolator Model 88205 permits bi-directional connection of two RS232 devices with an electrical isolation voltage of 1000 Volts.

Function

The isolator supports all data and handshaking lines of 9 pin RS232 interfaces and has two mutually independent, active RS232 interfaces. Therefore the isolator can be used as a RS232 repeater device to double the permissible cable length by inserting the isolator in the middle of the transmission line.

Connectors

The DTE port of the isolator uses a 9-pin male SUB-D connector, while the DCE port uses an 9-pin female SUB-D connector. The connector pin assignments are shown in the table below:

Pin#	RS232 female conn.	Pin#	RS232 male conn.
1	DCD (output)	1	DCD (input)
2	RxD (output)	2	RxD (input)
3	TxD (input)	3	TxD (output)
4	DTR (input)	4	DTR (output)
5	GND (signal ground)	5	GND (signal ground)
6	DSR (output)	6	DSR (input)
7	RTS (input)	7	RTS (output)
8	CTS (output)	8	CTS (input)
9	RI (output)	9	RI (input)

RS232 application with hardware handshake

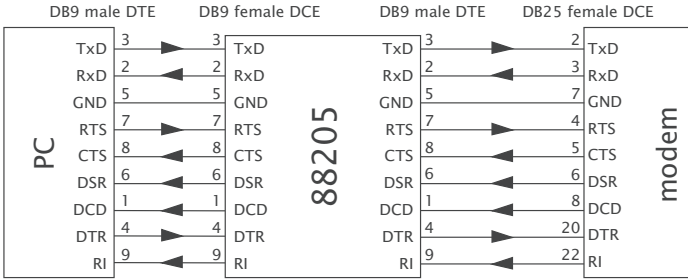

RS232 application with software handshake

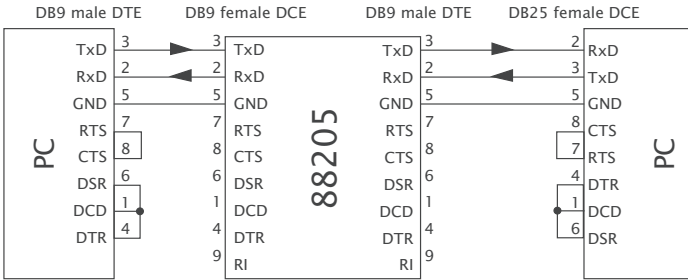

Technical Data

Baud rate:	0..115,200 baud
Data format:	any format
Supported signals:	RxD, TxD, RTS, CTS, DSR, DCD, DTR, RI
RS232 DTE adapter:	9-pin male SUB-D adapter
RS232 DCE adapter:	9-pin female SUB-D adapter
Electrical isolation:	both ports from each other and from power supply with a dielectric strength of 1000 volts DC
Power supply:	12..24V DC/AC
Current consumption:	typ. 85mA @12V, 45mA @24V DC
Power connection:	Plug-in screw terminal, 5.08mm spacing, labeled „L+“ and „M“
Ambient temperature:	storage: -40..+70°C operation: 0..+60°C
Relative humidity:	5..95% rH (non-condensing)
Housing:	small plastic housing for top hat rail mounting
Dimensions:	105x75x22mm
Device weight:	approx. 100g
Delivery:	RS232 Galvanic Isolator

RS422 / RS485 Isolator, Model 66201 & 66203

Both W&T RS422/RS485 Isolator models 66201 and 66203 permit bi-directional connection of two RS422 devices or RS485 bus systems with an electrical isolation voltage of 1000 Volts.

Function

In RS422 mode the isolators support one data and one handshaking line in each direction. In RS485 mode the isolators support 2-wire and 4-wire bus systems.

Connectors

The two ports of the devices use DB9 male connectors. The connector pin assignments are shown in the table below:

Pin#	RS422/485 signal
1	data out A (-)
2	data in A (-)
3	handshake out A (-)
4	handshake in A (-)
5	signal GND
6	data out B (+)
7	data in B (+)
8	handshake out B (+)
9	handshake in B (+)

Overvoltage protection (Model 66203 only)

The maximum differential voltage allowed to reach the RS485 transceiver chip of the isolator from the outside is around $\pm 12...14V$ according to the data sheets. Voltage exceeding this amount will inevitably result in destruction of the line drivers.

The W&T Isolator model 66203 has integrated overvoltage protection which uses suppressor diodes to limit the maximum voltage to approx. $\pm 9V$.

This overvoltage protection is limited of course by the capacity of the protection diodes used, which can let through a current of 20A for a short time. This means it may not be a substitute for a lightning surge arrester for long cables in exposed locations (e.g. in the mountains).

Operating mode

The isolator can be set for three operating modes by DIP switch setting on the RS422/RS485 interface module. The selectable operating modes are briefly described here:

Galvanic Isolation for RS422 connections

One data channel and one handshake channel in each direction are available. The RS422/RS485 receivers and transmitters are always active in this operating mode.

Galvanic Isolation for RS485 4-wire bus systems

One data channel in each direction is available. The RS485 output driver is activated automatically with each transmission of data, and goes to the high impedance state again after the end of transmission. The RS485 receiving channel is always active in this operating mode.

Galvanic Isolation for RS485 2-wire bus systems

One data channel in each direction is available. The RS485 output driver is activated automatically with each transmission of data, and goes to the high impedance state again after the end of transmission. The RS485 receiving channel is deactivated when the driver is on, but is switched on when the driver is in the high impedance state.

Setting the operating modes

Please see the following table for an explanation of the operating mode DIP switch:

Operating mode	SW1	SW2	SW3	SW4	SW5	SW8
RS422	OFF	OFF	OFF	ON	OFF	OFF
RS485, 4-wire bus system	OFF	ON	OFF	ON	OFF	OFF
RS485, 2-wire bus system	ON	ON	OFF	ON	OFF	OFF

Setting the switching time

In both RS485 modes of the isolator the respective RS485 transmitter is automatically placed in the active state as soon as data transmission begins, and turned off again with a time delay at the end of the data telegram.

Switch S8 on the DIL switch bank of the interface modules can be used to set the switching time for the respective interface between send and receive mode to values of 10 μ s (S8 = „on“) and 50 μ s (S8 = „off“).

The required value for the switching time depends on a number of factors, among which are the baud rate, the response time of the accessed RS485 slaves, and the overall length of the bus system. For this reason it is not feasible to provide an ideal value for all conceivable applications.

In practical terms you should use a value for the switching time which lies in the range of a bit time. At 115.200 kBaud this would correspond to a time of approx. 10 μ s, and at slower baud rates you should choose the longer of the two times.

Other values are possible by means of a factory component change – please contact us if this is something you need.

Termination

For all RS485 operating modes it is essential that the bus system be terminated with a termination network which assures a defined rest state in the high-impedance phases of bus operation.

The bus system can be connected to a termination network by closing switches #6 and #7 on the interface module:

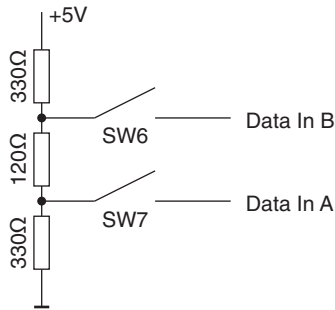

Applications

RS422 application with hardware handshake

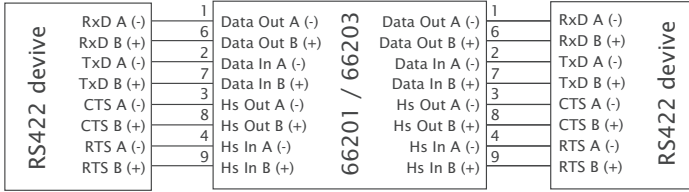

RS485 2-wire application

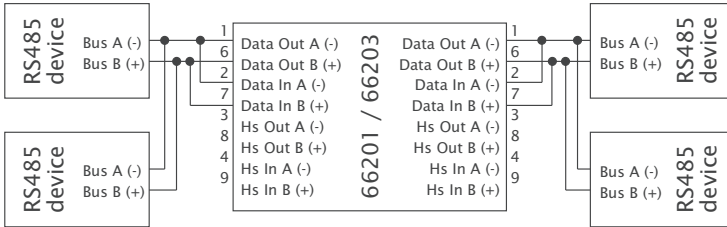

Technical Data

Operating modes:	RS422 RS485 2/4 wire mode with automatic control
Switchover delay:	66201: approx. 10 μ s 66203: selectable 10 μ s/50 μ s from transmit to receive for RS485 automatic control (can be factory changed on request)
Baud rate:	0..3 Mbaud
Data format:	any format
Supported signals:	RxD, TxD, CTS, DTR
RS422/RS485 adapter:	9-pin male SUB-D adapter
Termination:	Switchable termination network for RS485 operation
Electrical isolation:	both ports from each other and from power supply with a dielectric strength of 1000 volts DC
Overvoltage protection:	Model 66203 only: limiting of differential voltage by suppressor diodes to $V_{max} = 9,2V$ ($I_{max} = 20A$, $t = 10/1000\mu s$)
Power supply:	12..24V DC/AC
Current consumption:	typ. 70mA @12V, 35mA @24V DC
Power connection:	Plug-in screw terminal, 5.08mm spacing, labeled „L+“ and „M“
Ambient temperature:	storage: -40..+70°C operation: 0..+60°C
Relative humidity:	5..95% rH (non-condensing)
Housing:	small plastic housing for top hat rail mounting
Dimensions:	105x75x22mm
Device weight:	approx. 100g
Delivery:	RS422/RS485 Galvanic Isolator

RS232 Line Driver Set, Model 80201

The W&T Line Driver Set Model 80201 permits bi-directional connection of two RS232 devices over a distance of up to 1.200 meters.

Function

The line driver set consists of two identical interface modules RS232 <> RS422 and supports one data and one handshaking line in each direction.

To avoid the effects of ground potential difference, both ports of the line driver modules are isolated from each other and from the power supply with a dielectric strength of 1000 volts.

The line driver modules must be connected to the RS232 devices by additional shielded serial cables. The pinout of the RS232 cables is shown in the chapter „Applications“ of this manual.

Connectors

The two ports of the W&T line driver module 80201 use DB9 male connectors. The connector pin assignments are shown in the table below:

Pin#	RS232 signal
2	data in
3	data out
4	handshake out
5	signal GND
8	handshake in

Pin#	RS422-Signal
1	data out A (-)
2	data in A (-)
3	handshake out A (-)
4	handshake in A (-)
5	signal GND
6	data out B (+)
7	data in B (+)
8	handshake out B (+)
9	handshake in B (+)

Interconnecting cable

To ensure proper operation over long distances, 4-wire or 8-wire shielded twisted pair (STP) cable should be employed as interconnection cable. Because of the use of balanced RS422 interfaces, every transmitted RS232 signal requires one wire pair of the interconnecting cable.

RS232 software handshake communications therefore require 2 pair STP cables, while communications with two additional hardware handshaking lines require 4 pair STP cables.

One cable pair must be used for the inverting line (A) and the non-inverting line (B) of the same signal type. The cable shield shall be connected to the shell of the RS422 interface at both ends of the interconnecting cable.

Applications

RS232 application with hardware handshake

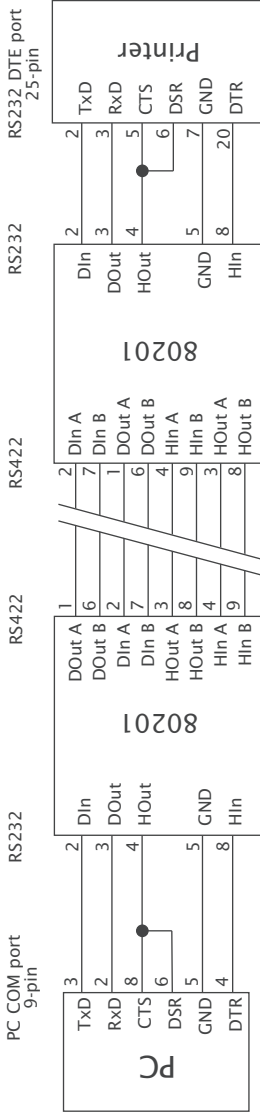

RS232 application with software handshake

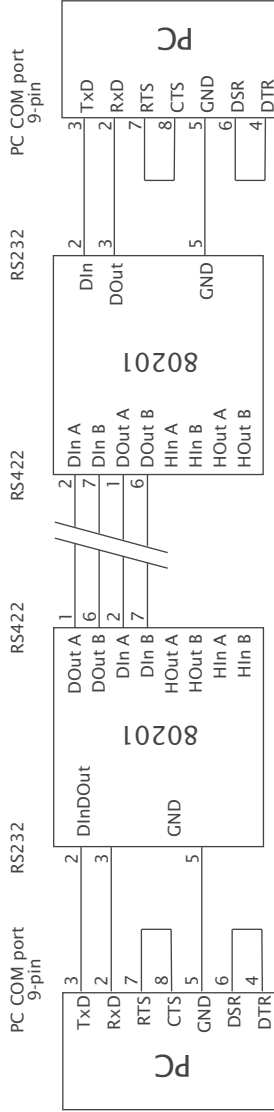

Technical Data

Baud rate:	0..115,200 baud
Data format:	any format
Supported signals:	RxD, TxD, CTS, DTR
RS232 adapter:	9-pin male SUB-D adapter
RS422 adapter:	9-pin male SUB-D adapter
Max. distance:	1200m
Electrical isolation:	both ports from each other and from power supply with a dielectric strength of 1000 volts DC
Power supply:	12..24V DC/AC
Current consumption:	typ. 80mA @12V, 40mA @24V DC
Power connection:	Plug-in screw terminal, 5.08mm spacing, labeled „L+“ and „M“
Ambient temperature:	storage: -40..+70°C operation: 0..+60°C
Relative humidity:	5..95% rH (non-condensing)
Housing:	small plastic housing for top hat rail mounting
Dimensions:	105x75x22mm
Device weight:	approx. 100g
Delivery:	RS232 Line Driver Set

Wiesemann & Theis GmbH
Porschestr. 12
42279 Wuppertal / Germany

Mail info@WuT.de
Web www.WuT.de

Tel. +49 (0) 202/2680-110
Fax +49 (0) 202/2680-265